



1.0 SAFETY INFORMATION

- The provision of the electrical supply and the connection of the unit to the mains must be carried out by a qualified electrician.
- Isolate from power supply before removing any covers. During installation / maintenance ensure all covers are fitted before switching on the mains supply.
- All-pole disconnection from the mains as shown in the wiring diagram must be incorporated within the fixed wiring and shall have a minimum contact separation of 3mm in accordance with latest edition of the wiring regulations.
- This unit must be earthed.
- Ducting must be securely fixed with screws to the spigot to prevent access to live parts. Duct runs terminating close to the fan must be adequately protected by suitable guards.
- If the supply cord is damaged, it must be replaced by the manufacturer, its service agent or similarly qualified persons in order to avoid a hazard.
- Precautions must be taken to avoid the back-flow of gases into the room from the open flue of gas or other fuel-burning appliances.
- This appliance should not be used by children or persons with reduced physical, sensory or mental capabilities or lack of experience and knowledge, unless they have been given supervision or instruction concerning the safe use of the appliance by a person responsible for their safety. Children shall not play with the appliance. Cleaning and user maintenance shall not be carried out by children.

1.1 Symbols



GENERAL WARNING

Signifies a general warning regarding hazard specified by supplementary information.



ELECTRIC SHOCK

This unit must be completely electrically isolated before any panels are removed. Check mains supply and control connections.



ROTATING PARTS

This unit contains fast moving rotational parts which may start automatically. It is the sole responsibility of the installer to adequately guard these components.



REFER TO INSTRUCTION MANUAL

Read and understand the installation and maintenance manual before installing, operating or maintaining this product.

1.2 Important Information

This manual contains important information on the safe and appropriate assembly, transport, commissioning, operation, maintenance, disassembly and simple troubleshooting of the product.

While the product has been manufactured according to the accepted rules of current technology, there is still a danger of personal injury or damage to equipment if the following general safety instructions and the warnings contained in these instructions are not complied with.

- **Read these instructions completely and thoroughly before working with the product.**
- **Keep these instructions in a location where they are accessible to all users at all times.**
- **Always include the operating instructions when you pass the product on to third parties.**

1.3 Personal Protective Equipment

The following minimum Personal Protective Equipment (PPE) is recommended when interacting with Nuair product:

- **Protective Steel Toed Shoes** - when handling heavy objects.
- **Full Finger Gloves (Marigold PU800 or equivalent)** - when handling sheet metal components.
- **Semi Fingerless Gloves (Marigold PU3000 3DO or equivalent)** - when conducting light work on the unit requiring tactile dexterity.
- **Safety Glasses** - when conducting any cleaning/cutting operation or exchanging filters.
- **Reusable Half Mask Respirators** - when replacing filters which have been in contact with normal room or environmental air.

Nuair would always recommend a site specific risk assessment by a competent person to determine if any additional PPE is required.

2.0 INTRODUCTION

The information contained in this document provides details of installation, operation and maintenance for installers and users of the XBOXER XBC Supply and Extract Ventilation Unit with Heat Recovery.

This supply and extract air handling unit range comprises a combination of high efficiency centrifugal fans with EC motors, a Counterflow design plate heat exchanger, filters, optional heaters (LPHW and Electric) and a casing with high mass acoustic treatment.

A range of matched, close coupled attenuators with a similar construction method to that of the unit is available. The attenuators can be flipped for positioning on the left or right of the fan unit (Figure 1) allowing flexibility for duct layout.

Attenuators are available in 1050, 1250 and 1600mm lengths and a matching attenuator flange is attached to the fan unit.

General information regarding performance and specifications for the equipment may be obtained from our Technical Literature, and/or project specific documentation.

1 Unit Layout Overview

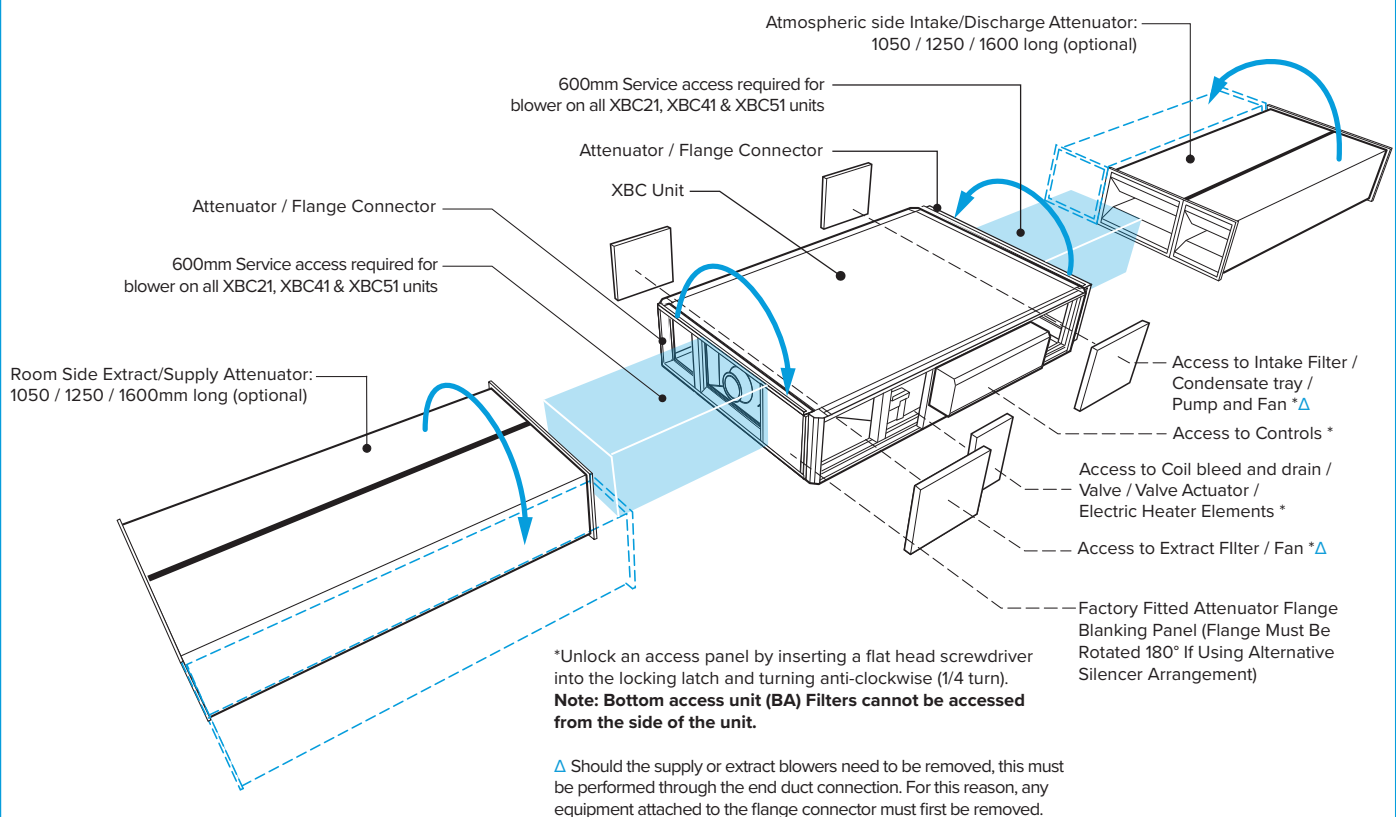

2.1 Code Description

1	2	3	4	5	-	6	7	8	-	9	10	11	12	13	14
XB	C	10	H	A	-	L	H	4	-	E	P	L	S	1	S

1. Range: **XB** = XBOXER
2. HX Type: **C** = Counterflow
E = Enthalpy*
3. Unit Size: **10, 15, 25, 45, 55, 65**
4. Unit Layout: **H** = Horizontal
5. Filter Grade: **A** = G4 Supply & G4 Extract Panel Filters (Spare Included)
6. Heating Type: **E** = Electric
L = LPHW
N = No Heating
7. Heater Size: **H** = High Duty
L = Low Duty
N = No Duty
8. LPHW Valve Type: **4** = 4 Port Valve (3 way with bypass)
N = No Valve
9. Control Type: **E** = Ecosmart Classic Control
N = No Control
10. Constant Pressure Controls: **-** = Not Available
P = Constant Pressure
11. Controls Handing: **L** = Left Hand
R = Right Hand
12. Filter Access: **B** = Bottom Access
S = Side Access
13. Unit Finish: **1** = Standard
4 = Coastal (C4**)
14. Unit Roof: **S** = Standard Unit (No Roof)
W = Twin Pitched Roof (Factory Fitted)

*Enthalpy variants do not include a condensate pump or condensate connection. It is important to ensure that safe access is available to the control, filters and other accessible parts. Bottom access units are highly recommended for this type of application. Contact Nuairé for advice.

** This units coastal finish has been designed to withstand an External C4 Atmospheric Corrosivity Category as per BS EN ISO 12944-2:2017 providing that it is installed and maintained as per the manufacturer's instructions and general Warranty Guidance Notes found in our conditions of sale.

3.0 MECHANICAL INSTALLATION

Installation must be completed by competent persons, in accordance with good industry practice and should conform to all governing and statutory bodies i.e. IEE, CIBSE, etc.

3.1 Unit Access

In this product range, several unique concepts have been implemented with a view to simplifying the installation design. Nuairé recommend as best practice guidance, to allow for a minimum of around 600mm clearance. Whilst an absolute minimum access of 250mm is possible, access in this situation is difficult and does not allow for major maintenance including component replacement.

1. The unit configuration is such that the supply and discharge connections are positioned at the centre. The corresponding Intake and Extract connections may be positioned on either side of the unit, allowing greater flexibility in the layout of ductwork in the space, (Figure 4) with the blanking panel re-positioned to suit.

2. The standard horizontal unit configuration is shown in Figure 5. Unit handing information will not be requested for this range, and units will be supplied in this format as standard.

3. With absolute minimum clearance, the unit may be connected to the power supply and control connections since the control may be rotated by 90 degrees to face downwards. (Cable connections must allow for the relative movement when the control is re-positioned). Filters may be changed and the fans, coils, heat exchanger and condensate tray may be inspected and cleaned if necessary.

4. The LPHW and Electrical heater settings, coil bleed and drain, and all other control adjustments are similarly accessible (Figure 1).

5. Side access, where possible, is preferred in all cases in terms of safe working access to the equipment under the CDM regulations.

6. Where these arrangements are not suitable, the Consultant's and Contractor's project specific requirements will always be accommodated where possible.

7. Bottom access only units (Example code: XBC25HA-LH2-E-LB1S), provide access to filters only (Figure 7). Remove the filter covers on the front panel of the unit by gripping the two circular tabs either end of the filter covers and pulling away from the unit. The filter can now be extracted. Once the filters have been inspected return or replace them as necessary.

Filter removal is not available from the sides on these units. Bottom access units must be installed with the following minimum clearance below the units. **XBC15 = 225mm, XBC25 = 300mm, XBC45 = 360mm, XBC55 = 480mm and XBC65 = 630mm.**

Unit is shipped with 4x G4 filters in place, 2 of which are included as spares. For higher grade replacement filters contact Nuairé. Pressure drops will vary with filter grade and this change in pressure must be accounted for when commissioning.

Unlocking an access panel is achieved by inserting a flat head screwdriver into the locking latch groove and turning anti-clockwise (1/4 turn), keys are neither required nor provided.

2 Minimum Controls Clearance (Side Access Unit)

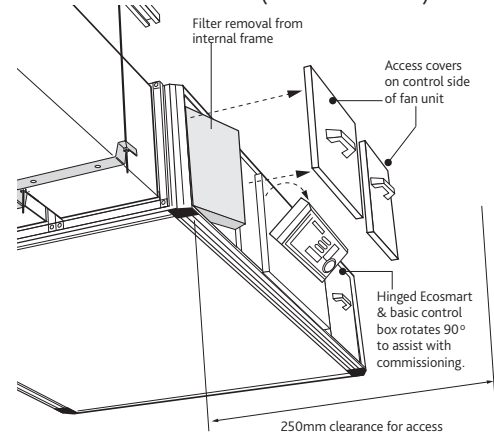

3 Side Access Unit Filters

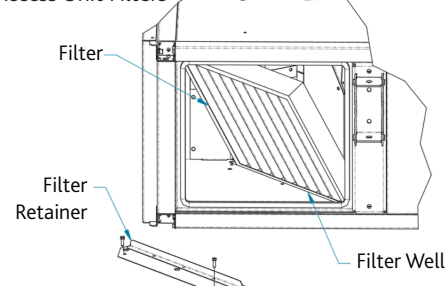

Filter Removal:
Remove filter retainer (2 x M5 screws)
Lower filter into filter well in the base
Tilt filter and remove through panel

4 Selectable Duct Connections (Top View)

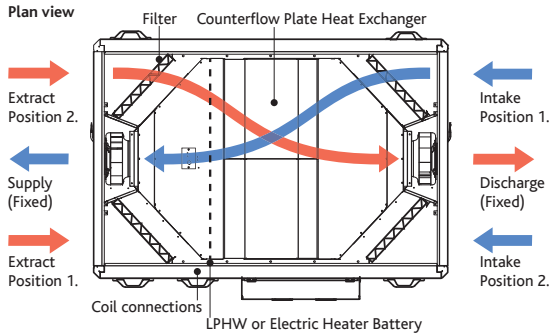

5 Right Handed (R) Arrangement (Top View)

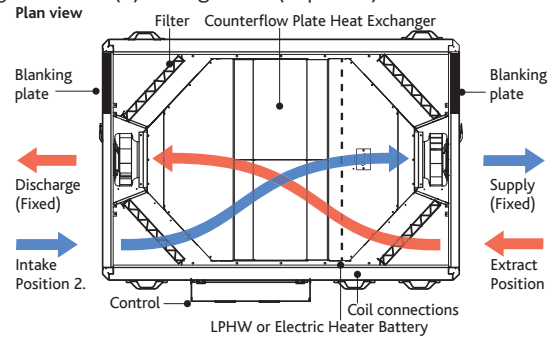

6 Left Handed (L) Arrangement (Top View)

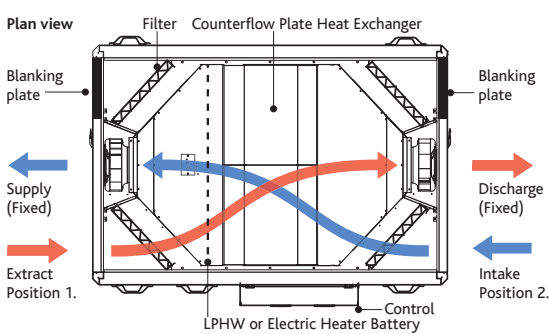

7 Bottom Access Unit Filters

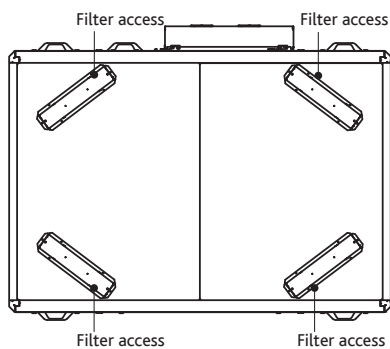

8 Unit Lifting

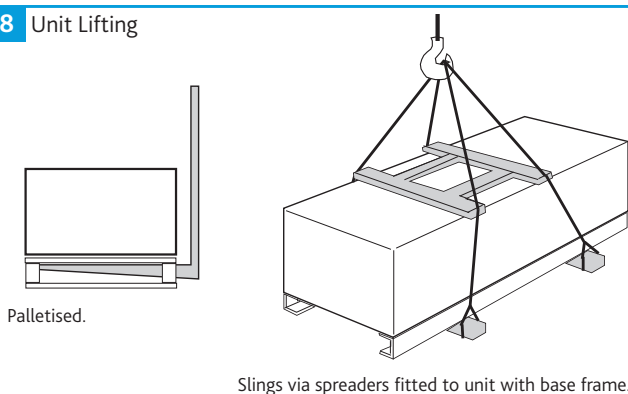

3.2 Delivery of Equipment

3.2.1 Receipt of Equipment

All equipment is inspected prior to despatch and leaves the factory in good condition. Upon receipt of the equipment an inspection should be made and any damage indicated on the delivery note.

Particulars of damage and/or incomplete delivery should be endorsed by the driver delivering the goods before offloading by the purchaser. No responsibility will be accepted for damage sustained during the offloading from the vehicle or on the site thereafter. All claims for damage and/or incomplete delivery must be reported to Nuair within two days of receipt of the equipment following guidance in our terms & conditions of sale.

3.2.2 Offloading and Handling

The weight of the unit modules and palletised items is displayed on the unit rating plate or on the packaging. Some of the modules have an uneven weight distribution, and this will be indicated by labelling where appropriate. Ensure that lifting and handling equipment is adequately rated. Offloading and positioning of the equipment is the responsibility of the purchaser.

Spreaders should be used when lifting with slings to avoid damage to the casings. Care must be taken to ensure that slings are correctly positioned to avoid crushing and twisting of the unit castings.

Where channels and/or support frames are bolted to the underside of the unit casing, slings or fork-lift arms should be positioned to locate in the apertures in the channels. If lifting eyes have been supplied / fitted it is recommended that they are used.

XBOXER XBC units will be delivered to site in one section and will be labelled with the direction of air flow. The direction convention must be observed during assembly.

The unit may only be operated in its intended horizontal installation plane and must be fully levelled during installation (this is essential to ensure that condensate drains correctly).

See Section 3.5 for dimensions and weights.

3.2.3 Storage

The equipment must be stored in a dry, internal location. Ductwork connection apertures shall be sealed against the ingress of dust, water and vermin. Do not stack units, modules or components.

Where fans are to be stored or bonded for extensive periods follow the Warranty Guidance Notes found in our conditions of sale.

3.3 Assembly of Equipment

Units must be installed in accordance with good industry practice.

These units may only be mounted horizontally and must be fully levelled in the horizontal plane. The units are heavy, and should be mounted using the fixing brackets supplied or other suitable methods of support. The supporting structure must be assessed for structural suitability.

Heat recovery components and modules that incorporate cooling coils may produce condensation during use. An insulated drip tray and condensate pump is provided. The drain connection must be connected to a suitable drainage point (Figure 23 on page 12 for details).

3.4 Condensate Pump (Not Applicable To XBE Units)

3.4.1 Condensate Pump Alarm

The condensate pump incorporates an alarm function. If the water level in the condensate tray exceeds a maximum level (for example, as a result of the discharge tube becoming blocked or frozen), the alarm contact will open. This contact is internally connected to the heat exchanger bypass actuator, and the unit will automatically be placed into bypass mode, preventing further condensate production. Unit operation will otherwise be unaffected.

3.4.2 Condensate Pump Specification

Maximum flow rate = 12 l/h
Maximum head = 20m Vertical, 100m Horizontal
Pipe Connection size (Condensate) XBOXER XBC = 8 mm

LPHW Coils, if fitted, are tested during manufacture to 16 Bar (using dry compressed air). Coil and valve assemblies are similarly tested to 10 Bar. The operation of standard equipment is rated to PN6.

Electrical connections to the unit shall be made in accordance with the appropriate product and installation wiring diagrams provided, and shall use appropriately sized and rated cables.

Only the prepared apertures in the unit casing may be used for cable entry. Do not drill or cut the unit casing for this purpose. Cable access points are provided at the ends of the control enclosure.

If the control is rotated to aid connection of cables, please ensure that sufficient flexibility is provided in the final connection run.

To avoid conflict with the unit access panels, it is recommended that electrical and plumbing service connections to the unit are run at 90 degrees to the main air flow axis.

Control circuit connections must be segregated (i.e. routed separately) by a minimum of 50mm from power connections.

The unit rating label shows the maximum electrical load of the equipment. Connections to the unit may include single phase supply connections, and a variety of control circuits.

Only the prepared apertures in the unit casing may be used for cable entry. Do not drill or cut the unit casing for this purpose.

The equipment must be earthed and earth-bonded. Means of local isolation for maintenance purposes are generally required (by others). Ensure that all mains connections are isolated.

3.5 Dimensions & Weights

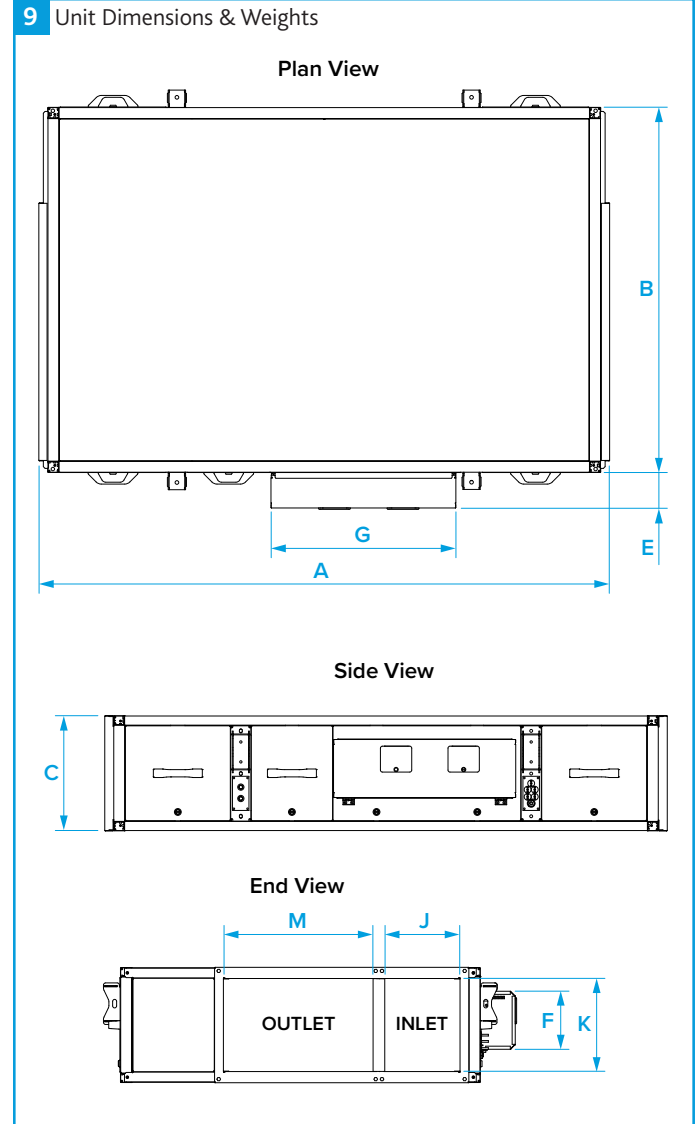

Unit Code	Unit Dimensions (mm)						Control Dimensions (mm)			Unit Weights	Packed Weights
	A	B	C	J	K	M	E	F	G	(kg)	(kg)
XBC10HA-***_***	1600	1000	260	238	220	347	130	210	640	195	261
XBC10HA-***_**W	1600†	1210	335	238	220	347	210	230	674	217	283
XBC15HA-***_***	1600	1000	260	238	220	347	130	210	640	195	261
XBC15HA-***_**W	1600†	1210	335	238	220	347	210	230	674	217	283
XBC25HA-***_***	1713	1160	340	252	302	471	130	210	640	242	308
XBC25HA-***_**W	1713†	1390	426	252	302	471	276	287	820	267	333
XBC45HA-***_***	1912	1262	400	270	360	531	130	210	640	298	405
XBC45HA-***_**W	1912†	1490	487	270	360	531	276	287	954	328	435
XBC55HA-***_***	1956	1562	472	397	430	587	130	210	640	375	546
XBC55HA-***_**W	1956†	1562	571	397	430	587	215	386	1000	410	581
XBC65HA-***_***	1913	1572	620	398	580	588	130	210	640	476	652
XBC65HA-***_**W	1913†	1796	725	398	580	588	215	514	1000	514	690

† Excludes length of overhanging weatherproof roof.

3.6 Hanging Bracket Positions

10 Unit with Hanging Brackets Attached

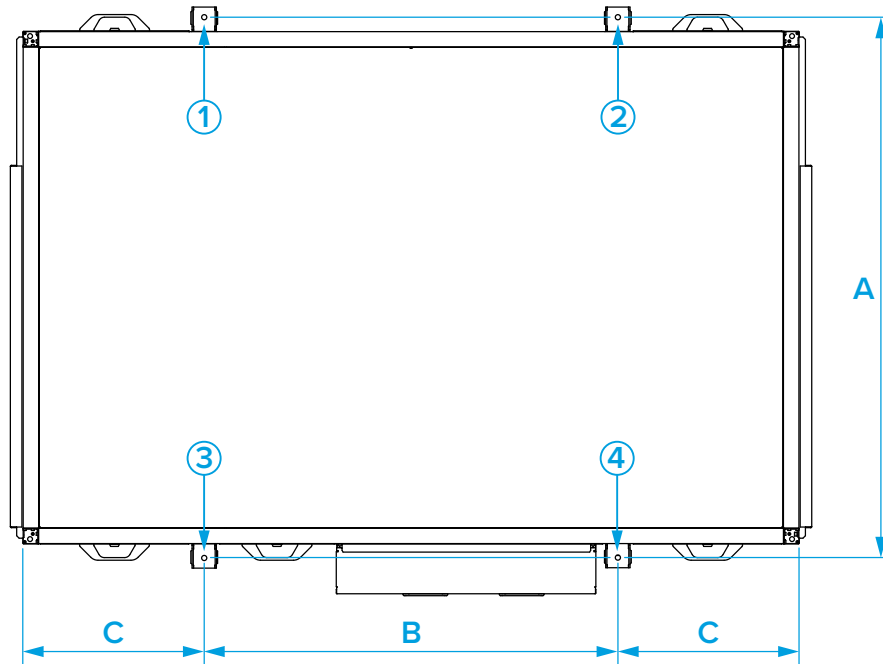

Unit Code	Dimensions to Hole Centres (mm)		
	A	B	C
XBC10HA-***_***	1068	830	385
XBC15HA-***_***	1068	830	385
XBC25HA-***_***	1232	884	415
XBC45HA-***_***	1332	1020	447
XBC55HA-***_***	1632	1052	424
XBC65HA-***_***	1644	1054	430

3.7 Flange Connector Dimensions (mm)

11 Flange Connector

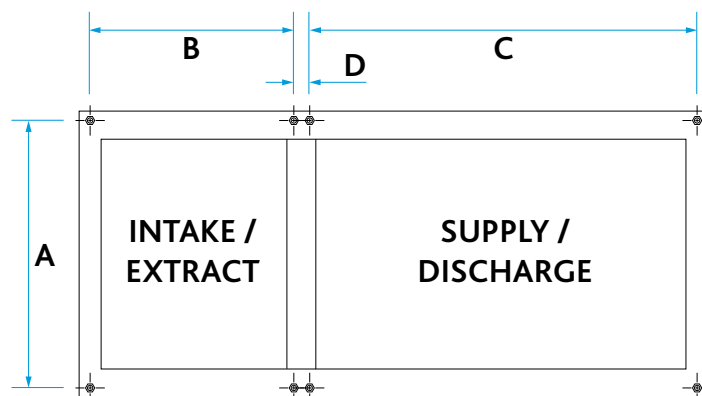

Unit Code	Dimensions to Hole Centres (mm)			
	A	B	C	D
XBC10HA-***_***	240	258	367	22
XBC15HA-***_***	240	258	367	22
XBC25HA-***_***	322	273	491	22
XBC45HA-***_***	380	291	552	22
XBC55HA-***_***	450	418	608	22
XBC65HA-***_***	600	418	608	22

3.8 Attenuator Dimensions & Weights

12 Attenuator Dimensions & Weights

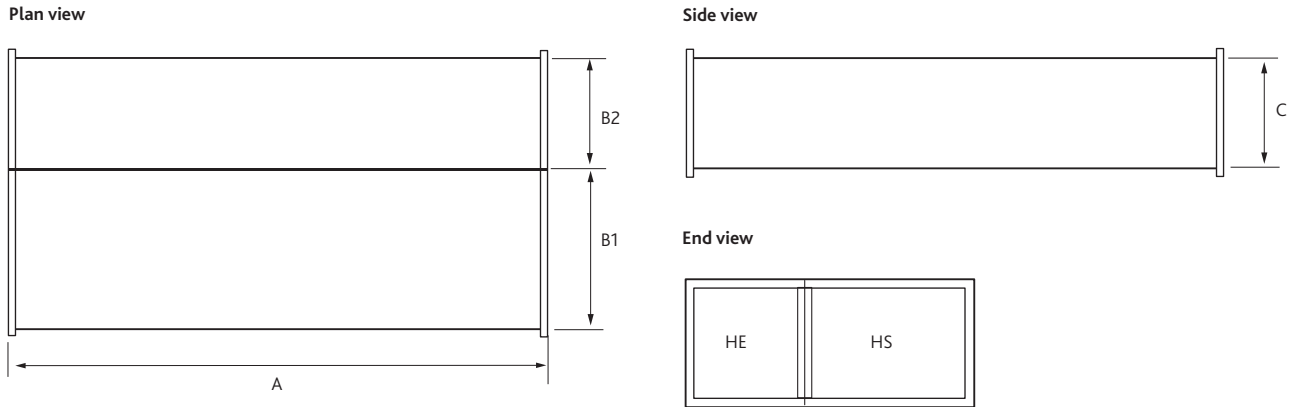

Attenuator Code	Dimensions (mm)				Attenuator Weights
	A	B1	B2	C	(kg)
XBC15-HS-MS10*	1050	347		220	30
XBC15-HE-MS10*	1050		238	220	24
XBC15-HS-MS12*	1250	347		220	35
XBC15-HE-MS12*	1250		238	220	29
XBC15-HS-MS16*	1600	347		220	44
XBC15-HE-MS16*	1600		238	220	36
XBC25-HS-MS10*	1050	471		302	29
XBC25-HE-MS10*	1050		252	302	29
XBC25-HS-MS12*	1250	471		302	34
XBC25-HE-MS12*	1250		252	302	34
XBC25-HS-MS16*	1600	471		302	42
XBC25-HE-MS16*	1600		252	302	42
XBC45-HS-MS10*	1050	531		360	32
XBC45-HE-MS10*	1050		270	360	32
XBC45-HS-MS12*	1250	531		360	40
XBC45-HE-MS12*	1250		270	360	37
XBC45-HS-MS16*	1600	531		360	47
XBC45-HE-MS16*	1600		270	360	47
XBC55-HS-MS10*	1050	588		430	32
XBC55-HE-MS10*	1050		398	430	36
XBC55-HS-MS12*	1250	588		430	37
XBC55-HE-MS12*	1250		398	430	42
XBC55-HS-MS16*	1600	588		430	47
XBC55-HE-MS16*	1600		398	430	52
XBC65-HS-MS10*	1050	588		580	43
XBC65-HE-MS10*	1050		398	580	46
XBC65-HS-MS12*	1250	588		580	51
XBC65-HE-MS12*	1250		398	580	54
XBC65-HS-MS16*	1600	588		580	63
XBC65-HE-MS16*	1600		398	580	67

2 attenuator flange connections are attached to every unit. Add 60mm to dimension 'A' to include both flanges for standard (no roof) units.

3.9 90° Bend Attenuator Dimensions & Weights

13 Attenuator Dimensions & Weights

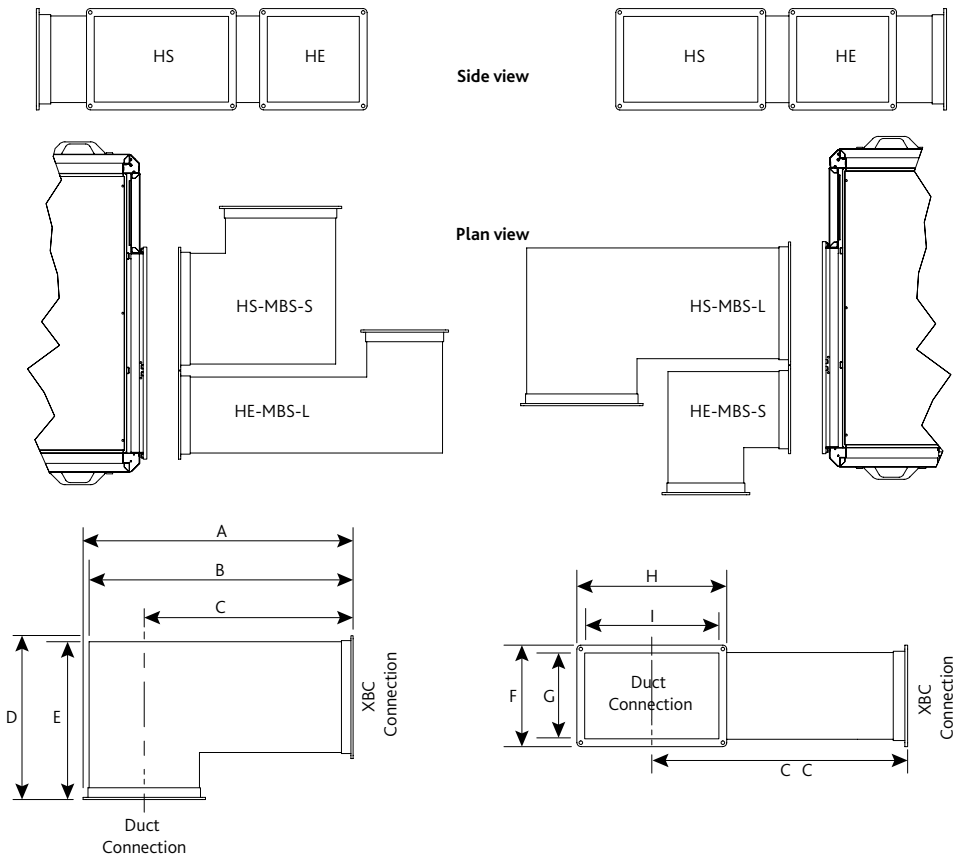

Attenuator Code	Unit Dimensions (mm)									Attenuator Weights (kg)
	A	B	C	D	E	F	G	H	I	
XBC15-HS-MBS-S	515	496	322	515	496	260	220	386	346	20
XBC15-HS-MBS-L	852	833	659	515	496	260	220	386	346	29
XBC15-HE-MBS-S	406	387	268	406	387	260	220	277	237	14
XBC15-HE-MBS-L	852	833	714	406	387	260	220	277	237	23
XBC25-HS-MBS-S	640	621	385	640	621	342	302	511	471	32
XBC25-HS-MBS-L	992	973	737	640	621	342	302	511	471	44
XBC25-HE-MBS-S	421	402	275	421	402	342	302	292	252	17
XBC25-HE-MBS-L	992	973	846	421	402	342	302	292	252	32
XBC45-HS-MBS-S	700	681	415	700	681	400	360	571	531	39
XBC45-HS-MBS-L	1070	1051	785	700	681	400	360	571	531	55
XBC45-HE-MBS-S	439	420	284	439	420	400	360	310	270	19
XBC45-HE-MBS-L	1070	1051	915	439	420	400	360	310	270	38
XBC55-HS-MBS-S	756	737	443	756	737	470	430	627	587	48
XBC55-HS-MBS-L	1253	1234	940	756	737	470	430	627	587	72
XBC55-HE-MBS-S	566	547	348	566	547	470	430	437	397	31
XBC55-HE-MBS-L	1253	1234	1035	566	547	470	430	437	397	58
XBC65-HS-MBS-S	756	737	443	756	737	620	580	627	587	54
XBC65-HS-MBS-L	1253	1234	940	756	737	620	580	627	587	82
XBC65-HE-MBS-S	566	547	348	566	547	620	580	437	397	36
XBC65-HE-MBS-L	1253	1234	1035	566	547	620	580	437	397	68

Coding:

HS - Denotes the type of silencer required for the supply or discharge.

HE - Denotes the type of silencer required for the extract or intake.

*Note: XBC15 silencers are also suitable for XBC10 units.

3.10 Unit Installation

The ventilation unit must be installed first, with consideration made for the length of the associated attenuators.

Installation of these units, including all external services and controls should be performed in accordance with all appropriate site procedures, and MUST conform to all governing regulations e.g. CDM, CIBSE, IEE, and in strict accordance with the applicable Building Regulations.

The correct installation position for the units shall be decided with due regard to access and maintenance requirements, and the objective of minimising the system ductwork resistance.

The recommended installation method is to use standard Unistrut channel secured to the slab / steelwork above the unit.

Four suitable drop rods should be secured to the Unistrut channel and extended to be fixed to the unit's four mounting brackets, (two each side of the fan unit) or to other horizontal supports by others where wider load distribution is required.

3.11 Attenuator Installation

It is recommended that additional Unistrut channels are used to support the matched attenuators. M8 Drop rods should be secured to the Unistrut channel and extended to be fixed to the four piece support brackets to be used on the underside of the attenuators (Figure 15).

Note – once the attenuators are supported and levelled, and immediately before securing the attenuator to the attenuator flange connector, remove the backing from the Foam Sealing Strip.

The attenuators must be secured to the unit using the screws provided.

14 Unit Installation

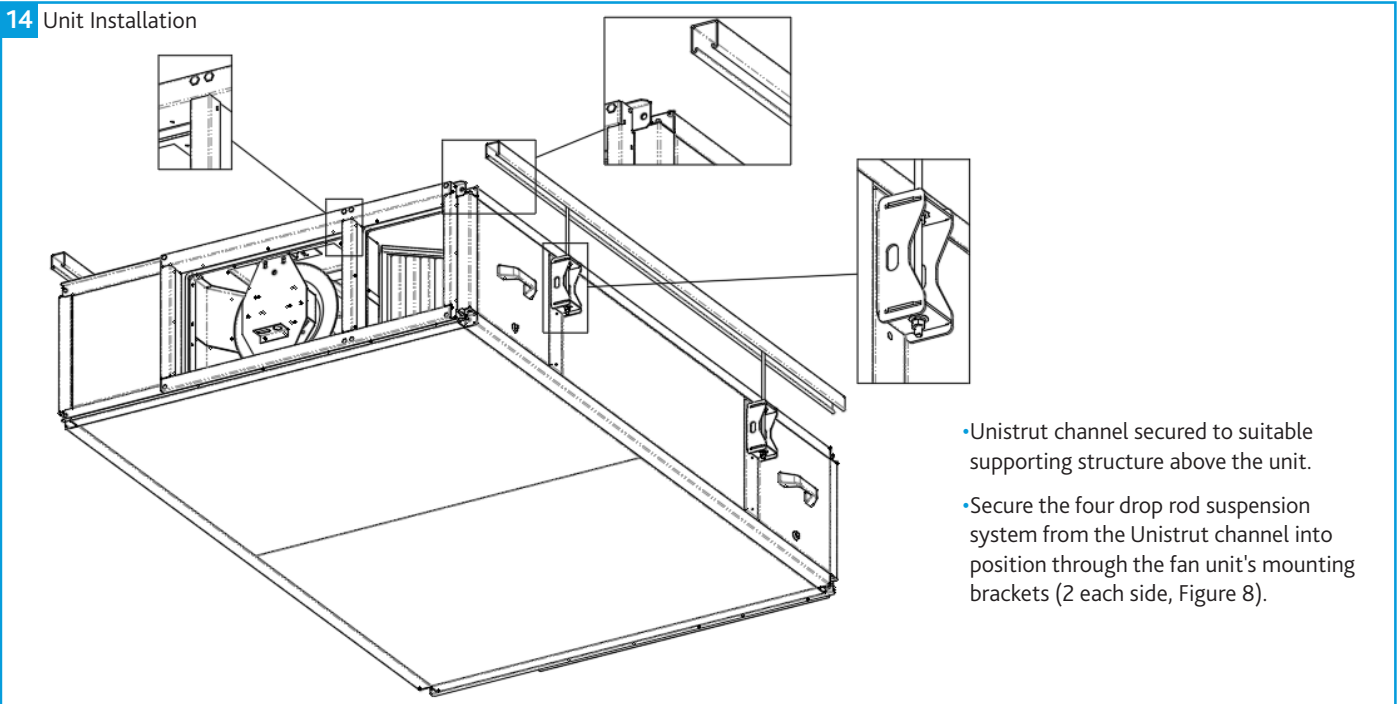

- Unistrut channel secured to suitable supporting structure above the unit.
- Secure the four drop rod suspension system from the Unistrut channel into position through the fan unit's mounting brackets (2 each side, Figure 8).

15 Attenuator Installation

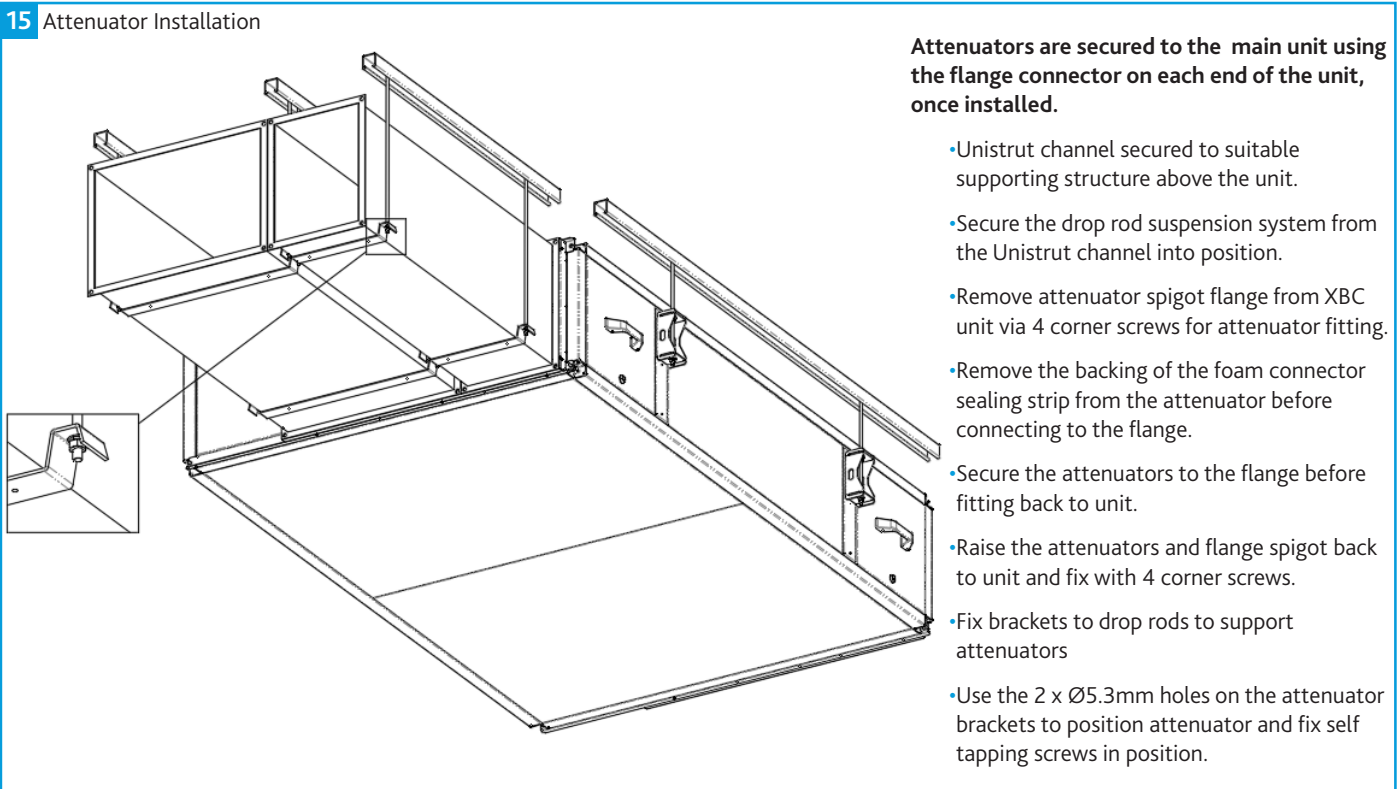

Attenuators are secured to the main unit using the flange connector on each end of the unit, once installed.

- Unistrut channel secured to suitable supporting structure above the unit.
- Secure the drop rod suspension system from the Unistrut channel into position.
- Remove attenuator spigot flange from XBC unit via 4 corner screws for attenuator fitting.
- Remove the backing of the foam connector sealing strip from the attenuator before connecting to the flange.
- Secure the attenuators to the flange before fitting back to unit.
- Raise the attenuators and flange spigot back to unit and fix with 4 corner screws.
- Fix brackets to drop rods to support attenuators
- Use the 2 x Ø5.3mm holes on the attenuator brackets to position attenuator and fix self tapping screws in position.

3.12 Weatherproof Kit Installation (If Supplied Separately)

Having installed the ventilation unit and attenuators, the Weatherproof Roof can now be installed if required.

The Roof assembly and control cover must be secured to the unit using the fixing channel provided.

When the roof has been installed onto the fan unit please ensure that the edges of the roof are fully sealed where it joins the fan unit. This does not apply to the control cover as this will have to be removed if necessary.

3.12.1 Weatherproof Kit Components

Item	Description	Quantity
A	Roof Assembly	1
B	Control Cover	1
C	Roof Fixing Bracket	4
D	Control Cover Fixing Channel	2

3.12.2 Optional Exhaust & Intake Terminals

Item	Description	Quantity
E	Exhaust Terminal	1
F	Intake Terminal	1

3.12.3 Terminal Part Codes

Unit Size	Exhaust Terminal	Intake Terminal
10	XBC10-EXHAUST-RT	XBC10-INTAKE-RT
15	XBC15-EXHAUST-RT	XBC15-INTAKE-RT
25	XBC25-EXHAUST-RT	XBC25-INTAKE-RT
45	XBC45-EXHAUST-RT	XBC45-INTAKE-RT
55	XBC55-EXHAUST-RT	XBC55-INTAKE-RT
65	XBC65-EXHAUST-RT	XBC65-INTAKE-RT

16 Weatherproof Kit Installation

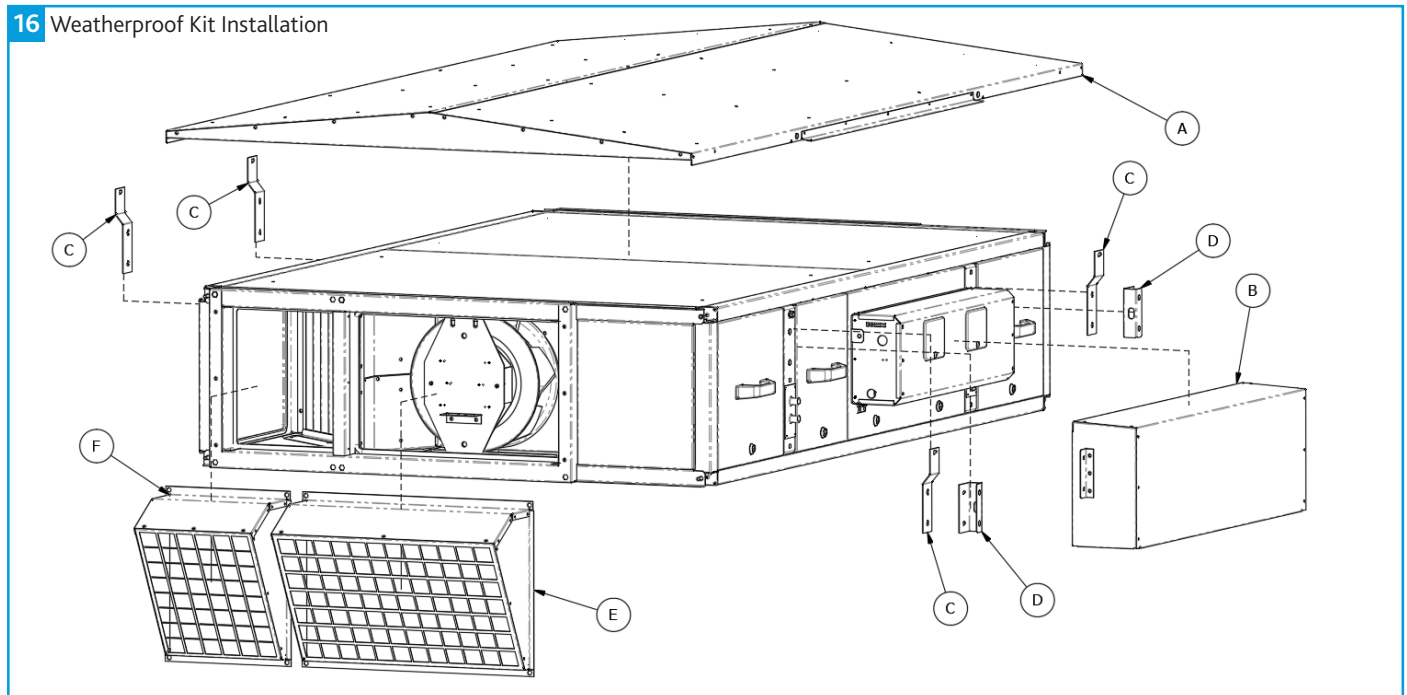

3.13 Motorised Dampers

If matched silencers of the same length (e.g. XBC15-HS-MS16 and XBC15-HE-MS16) are being fitted to the fan unit, the motorised damper (e.g. XBC15-MD and XBC15-MD-WP) should be fitted after the silencers (Figure 17) to ensure that breakout noise levels are kept to a minimum.

Where unmatched silencers are being fitted to the fan unit, the motorised damper should be fitted before the silencers.

The motorised damper units will be supplied loose and are designed to fit directly onto the flange connector (by others). The dampers feature fully interlocking parallel blades with a half inch diameter electroplated mild steel spindle. Nylatron bushes and external nylon/aluminium blade interconnection linkage. Fitted with Belimo SM230A-S drive open/drive close actuator complete with switch. Motorised damper wiring will require connection on site and possible extension of the cable looms.

17 Motorised Damper Installation

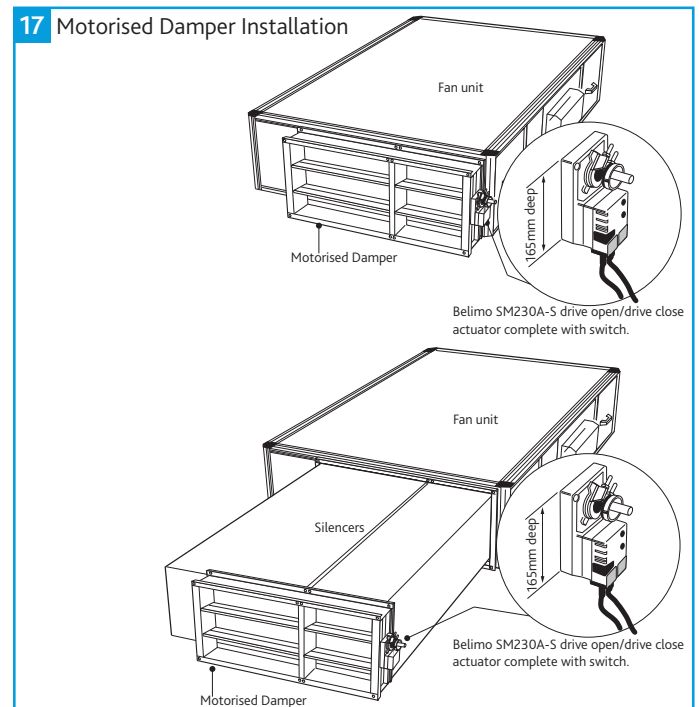

18 Damper Wiring

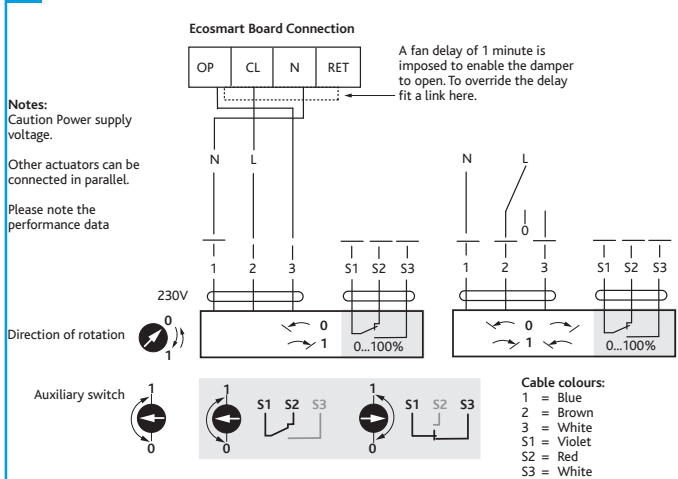

3.14 Constant Pressure (CP) Setup

Where applicable XBC Ecosmart constant pressure sensors are supplied to control the static pressure at the extract fan inlet. As a single fan speed control PCB is used within these units the supply fan will mirror this change in extract fan duty. This change in supply duty can be offset to become proportionate to the "o ADJ" pot setting (Section 5.4).

This set up is suitable for the majority of applications. When ancillaries with high pressure losses are fitted to the inlet side of the fan, the low pressure tapping must be moved from the fan chamber to a location upstream of the ancillaries, as shown below in Figure 19.

Failure to do this will result in excessive pressure being applied to the dampers at the rooms when the system is running in trickle mode.

3.15 Filter Pressure Switch

XBC units come with pre fitted pressure tappings for use with the dirty filter alarms (supplied loose) on both the supply and extract air streams. The IP54 pressure switch is equipped with a red visual LED alarm which will illuminate when the pressure reading surpasses that set by the adjustable knob.

3.15.1 Mounting Pressure Switch

Using the four mounting lugs provided, mount the pressure switches to a flat vertical surface using fixings appropriate for the surface. Any fixings used must have a maximum diameter of 8.0 mm. Do not tighten the fixings so much that the base of the device is deformed.

3.15.2 Connecting Pressure Tubing

Pressure tubing must not be kinked. Pay particular attention to this point if running hoses over an edge, it is better to form a loop.

For connection to the pressure switch, two fittings inherent in the housing are provided for hoses with an internal diameter of 6.0 mm.

- Connect a hose from the after filter (AF) pressure tapping to socket P1 which is located on the lower section of the housing.
- Connect a hose from the before filter (BF) pressure tapping to socket P2 which is located on the middle section of the housing.

After you have installed the hoses, it is essential to check them for tightness of fit at the connection points and to make sure that they run without any kinks.

3.15.3 Setting Switch Pressure

Make absolutely certain that there is no voltage on the electrical connections before you carry out any setting on the pressure switch, there is the possibility of an electric shock if you accidentally touch live parts.

Nuair recommend the pressure switch be set to trigger when the filters experience a 125 Pa increase above the clean filter resistance for the largest commissioned airflow rate. Use the adjustment dial to set the pressure at which the switch will trip. When the pressure falls below this set value, the switch returns to its resting position.

3.15.4 Switch Wiring

The cable gland is designed for cables with alternative sheath diameters of 7 mm or 10 mm. Only use these sizes. Otherwise the screw cable connection cannot seal adequately. The connections are intended for 6.3mm crimp-type sockets.

Remove switch cover. Wire the main unit to the terminal block within the switch as per the below wiring diagrams (Figure 19) ensuring the feed line is fused to suit Max 1.5A / 250 Vac. Refit switch cover.

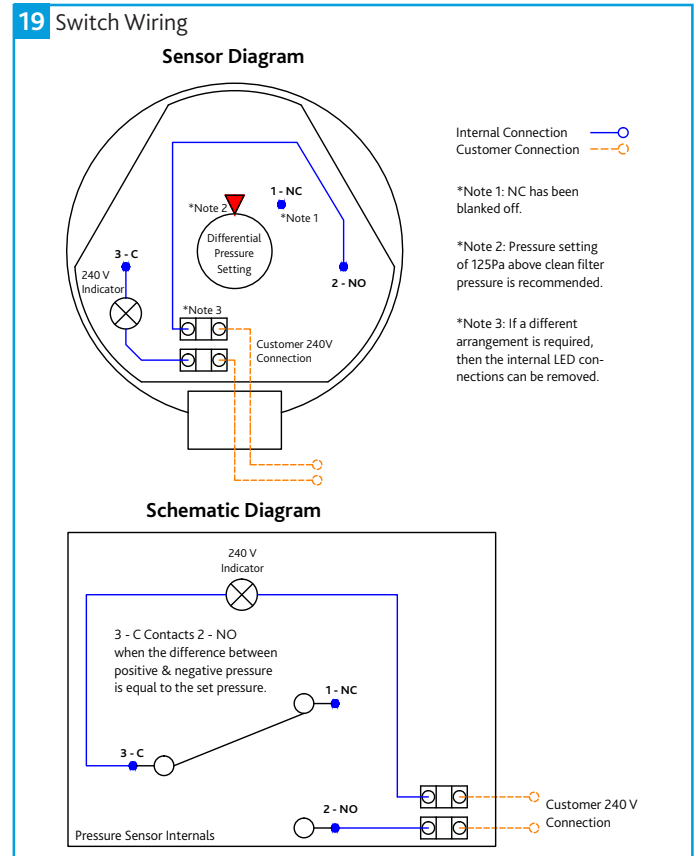

20 Constant Pressure Duct Tapping Locations

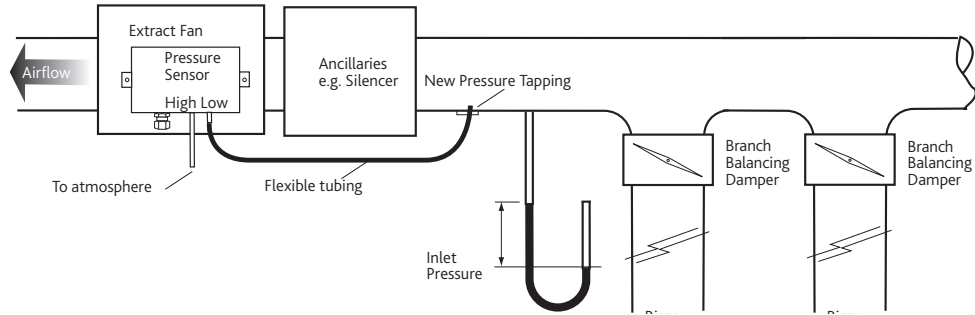

21 Pressure Tapping Layout (Left Hand Unit)

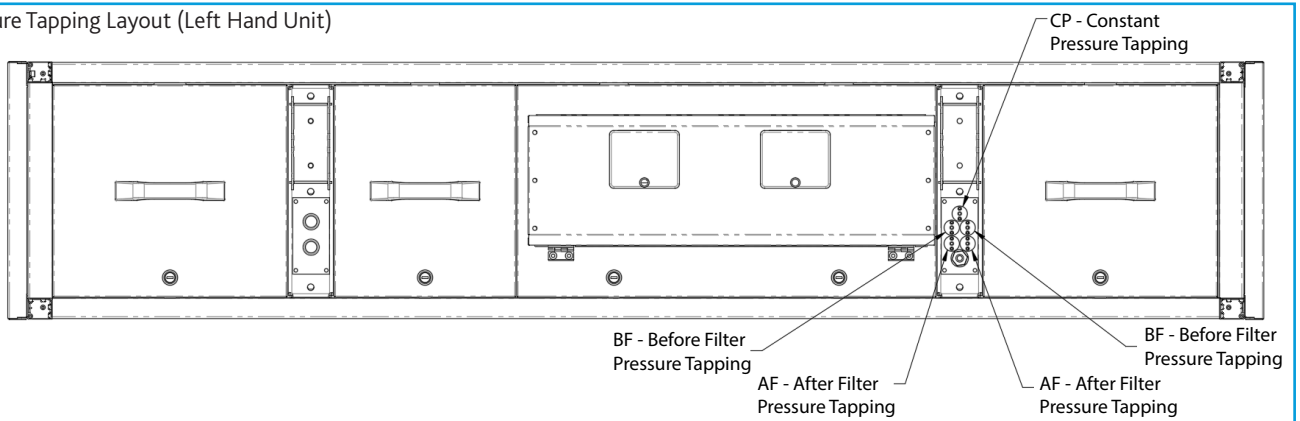

22 Pressure Tapping Layout (Right Hand Unit)

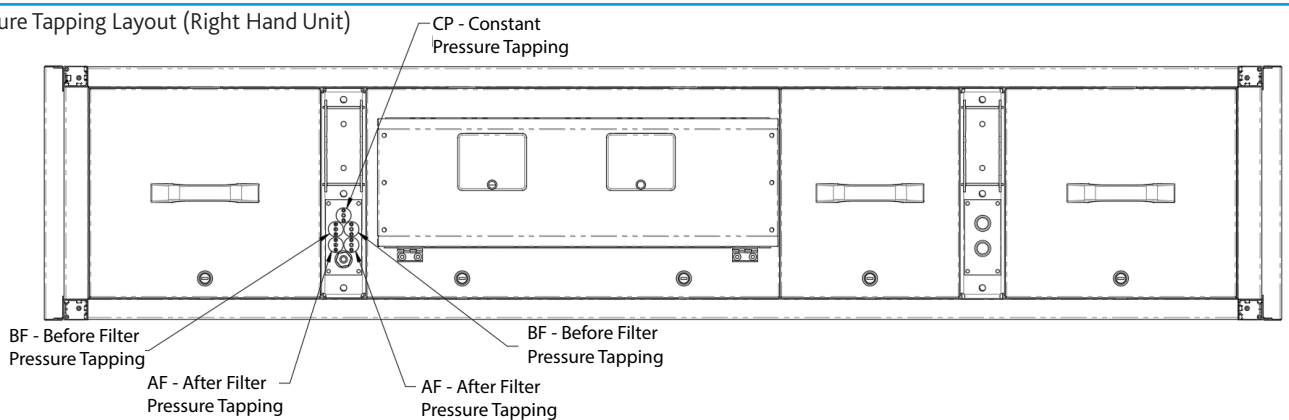

23 Coil & Condensate Drain Connections (Left Hand Unit)

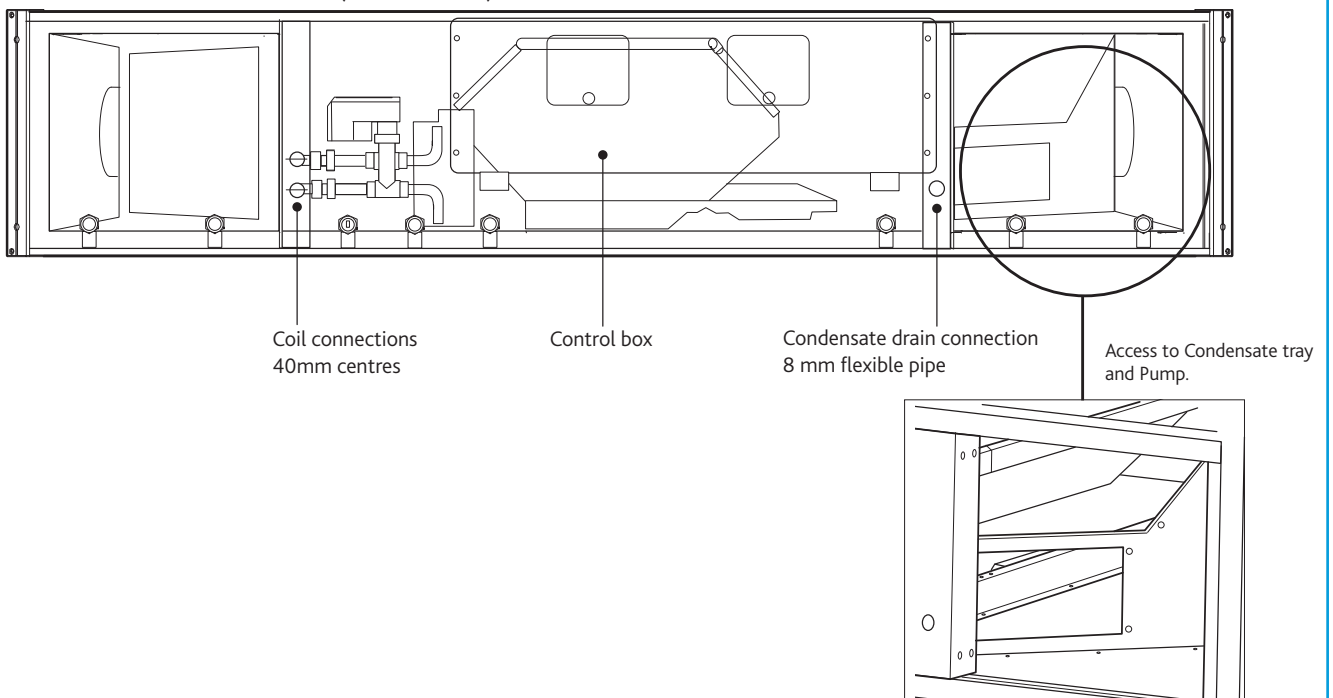

4.0 PRE-COMMISSIONING

Isolation - Before commencing work, make sure that the unit, switched live and Nuaire control are electrically isolated from the mains supply.

4.1 Filters

Remove filter access panels (observe and note airflow direction labels), inspect filters for contamination with construction debris, replace as necessary. Replace access panels.

Filter pressure drops will depend on actual flow rate and condition. Observe and record filter pressure drops after performance commissioning. Typically, filter "dirty" condition occurs when the initial filter "clean" readings have been increased by 125Pa.

If filter manometers, pressure switches or indicators have been fitted, they should be set or adjusted to reflect the commissioned system operation.

4.2 Heating Coils (LPHW)

Observe the Flow and Return connection labels on the unit. Drain and bleed valves are located on the coil. Other valves may be required in the system pipe-work depending on the installation (by others).

Where the wet system is at risk of frost damage, the addition of a proprietary anti-freeze solution to the water is recommended. Any frost protection offered by the unit's integral control system will not operate if the power supply to the unit is interrupted.

Ecosmart frost protection is activated on any Ecosmart unit fitted with LPHW heating, when the outlet air temperature is 4°C or below. The unit reacts by shutting down the fan to prevent a 'wind chill' effect reducing the temperature to a point whereby the coil could freeze and burst. The unit will also drive open the LPHW valve to a fully open position to allow full water flow through the coil and the main PCB will close the 'Heat demand' contacts. These contacts could be used to send a signal to activate the boiler and/or valve to open to provide heat if not already doing so.

Piped connections should be made to the unit using appropriate techniques, and all pipework must be independently supported.

No hot work is permitted within one metre of the unit.

Ensure that installed pipework runs do not prevent or restrict access to the unit at any point.

The completed installation (including the connections within the unit, as these may be disturbed during installation) shall be pressure tested to the project engineer's specification (This is a condition of the unit warranty).

4.3 Fan Sections

Access to the fan section is via lift off panels (Figures 1 & 23).

For non-Ecosmart units, wiring to the fan motor / unit terminal box should be mechanically protected and in made in accordance with the details on the motor name plate and diagram attached to the unit. With the unit electrically isolated, rotate the fan impeller / drive manually, checking that it spins freely.

Check all fixings are secure.

Units must not be operated without all access panels in place – damage to equipment or injury to personnel may result. Units must not be operated unless control interlocks are in place – damage to equipment may result.

Test run motor for condition and correct rotation. Check that the correct current overloads are fitted and that the current being drawn does not exceed the motor nameplate value. Excessive current normally indicates that the ductwork system resistance is different to design.

5.0 ELECTRICAL INSTALLATION

The electrical wiring must be carried out by competent persons, in accordance with good industry practice and should conform to all governing and statutory bodies i.e. IEE, CIBSE, COHSE etc.

5.1 Connections

5.1.1 Control Connections

Net - the 4 IDC plug-in connectors are provided for the connection of compatible sensors, manual controls and for linking the fans together under a common control. If more than 4 connections are required, the junction box (product code ES-JB) should be used (see data cable installation).

Switch Live (SL) Terminal - A signal of 100-230V AC will activate the fan (required at each control).

Note that a signal from an isolating transformer will produce an unpredictable result and is not recommended.

5.1.2 Damper Connections

OP - 230V 50Hz 1A max supply to open the damper

CL - 230V 50Hz 1A max supply to close the damper

N - Neutral supply to damper

RET - 230V AC return signal from the damper limit switch indicates the damper has reached its operating position. If the return signal is not present, the fan will wait for 1 minute before starting.

Note: If a damper is not fitted, connect a link wire from OP to RET. This will cancel the delay.

Where units are supplied in modular sections, it will be necessary to install and connect mains wiring between controls and devices such as motorised dampers, it may also be necessary to install and connect mains wiring between sensors and actuators.

Depending on final damper location, extension of the cable looms may be required.

5.1.3 Volt Free Relay Contacts

Note that the volt free contacts are not fused. If these are used to power any external equipment, the installer must provide adequate fusing or other protections.

Volt free relay contacts are rated at 5A resistive, 0.5A inductive.

Run Connections - Contacts closed when the fan is running

Fault Connections - No Fault = Contacts are closed

Fault - Contacts are opened

Heat Demand - Contacts closed when heating is selected.

5.1.4 Data Cable Connection

A 4-core SELV data cable is used to connect devices.

Do not run data cable in the same conduit as the mains cables and ensure there is a 50mm separation between the data cable and other cables. The maximum cable run between any two devices is 300m when it is installed in accordance with the instructions.

Please note that the total data cable length used in any system must be less than 1000m. Keep the number of cable joints to a minimum to ensure the best data transmission efficiency between devices.

5.1.5 Maximum Number of Devices

The maximum number of devices (including fans) that can be connected together via the cable is 32, irrespective of their functions.

5.1.6 Other Low Voltage Cables

Follow the basic principle (as d). Keep the cable run as short as possible, less than 50 metres. Use screened cable if cable length is more than 2m.

5.2 Electrical Information

Unit Without Electric Heater		Unit With Electric Heater		
Unit Code	FLC	Unit Code	Fan FLC	Heater
XBC10HA-(N/L)**	3.0 A	XBC10HA-E**	3.0 A	6.3 A
XBC15HA-(N/L)**	4.0 A	XBC15HA-E**	4.0 A	12.5 A
XBC25HA-(N/L)**	8.0 A	XBC25HA-E**	8.0 A	18.8 A
XBC45HA-(N/L)***	6.0 A	XBC45HA-E**	6.0 A	18.8 A
XBC55HA-(N/L)**	6.0 A	XBC55HA-E**	6.0 A	37.5 A
XBC65-HA-(N/L)**	6.0 A	XBC65HA-E**	6.0 A	37.5 A

5.3 Using Test Button (ES Control Only)

The test button allows the individual blowers within the unit to be checked for its operation. If the fan is running already, press the button once to stop the fan, press again to switch on the fan. **The fan will return to normal operation after 30 seconds.**

5.4 Supply & Extract Fan Speed Offset

This unit contains two fans and one control. Generally, the two fans operate at similar speeds, but the control includes an "O adjustment" for the slower fan (on the main circuit board).

If one of the fans needs to be run slower than the other, move the control extract or supply signal plug into the o header (Figure 24).

Use the o ADJ pot (Figure 28, Figure 29 and Figure 30) to turn the speed down.

Maximum turn down is 40%, i.e. reduce the drive signal to the slower fan up to 40%. Note the response of the fan to the drive signal may not be proportional at all signal values.

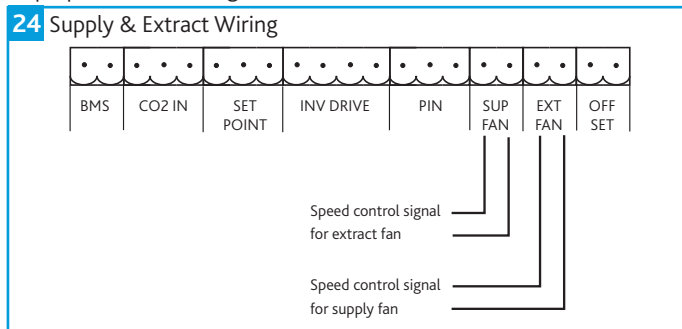

5.5 LED Indication

- PWR** GREEN: Power on & OK.
- Standby** LED on when fan is not running.
- Fan 1** GREEN: Fan 1 is running, RED: Fan 1 faulty.
- Fan 2** GREEN: Fan 2 is running, RED: Fan 2 faulty.
- Heating*** GREEN: Heating selected RED: Heating faulty.
- Cooling*** Not applicable. See note.
- Fault** LED on when a fault is present on unit.
- Frost*** Not applicable. See note.
- TX** LED on when the controller is transmitting data.
- RX** LED on when the controller is receiving data.

* Note that the control panel is common to all the Ecosmart products and will have indicators for functions that are not available in this particular fan. However these indicators will not be illuminated.

5.6 BMS Input Signals

The system's response to a 0-10V DC BMS signal is given in the following table.

The BMS signal will override any sensors and user control connected in the system. The voltage tolerance is +/- 125mV and is measured at the fans terminal.

	Ventilation Mode	Cooling Mode*	Heating Mode*
Local Control	0.00	-	-
OFF/ Trickle	0.25	-	-
Speed 1	0.50	0.75	1.00
Speed 2	1.50	1.75	2.00
Speed 3	2.50	2.75	3.00
Speed 4	3.50	3.75	4.00
Speed 5	4.50	4.75	5.00
Speed 6	5.50	5.75	6.00
Speed 7	6.50	6.75	7.00
Speed 8	7.50	7.75	8.00
Speed 9	8.50	8.75	9.00
Speed 10	9.50	9.75	10.00

5.7 Commissioning Settings

5.7.1 Maximum Airflow

- Ensure the power supply is switched off and that a link wire is connected from the supply L to the SL terminal. Unplug all items connected to the 'Net' connectors.
- Switch on the power supply.
- Wait for the fan to complete its self-test operation.

Measure the airflow using standard commissioning instruments at a suitable point in the ductwork. If adjustment is required, rotate the pot marked 'MAX' to obtain the desired airflow.

5.7.2 Minimum Airflow (Trickle)

- Repeat the same procedure as for maximum airflow above but without the link wire between supply L and SL terminal. Ensure the trickle switch is in the 'ON' position. Adjustment must be made on the pot marked 'Min'.

The minimum setting (20% of maximum air flow) must be below the maximum setting; otherwise minimum setting will be automatically set to be the same as the maximum.

5.7.3 Trickle Ventilation

Slide the 'trickle' switch 0 = Off, 1 = On. With 'trickle' on and power to unit, the fan will run at minimum speed until the switch live signal activates it to boost.

5.7.4 Overrun Time

A switched live of 100-230V at terminal SL will activate the fan.

When the switched live signal is removed the fan will overrun for period set by the dial 'SL run on' - adjust the desired overrun time between 1-60 minutes by rotating clockwise.

5.7.5 Air Off Temperature

The adjustment knob is located in the control pack and must be set to the desired 'air off' temperature.

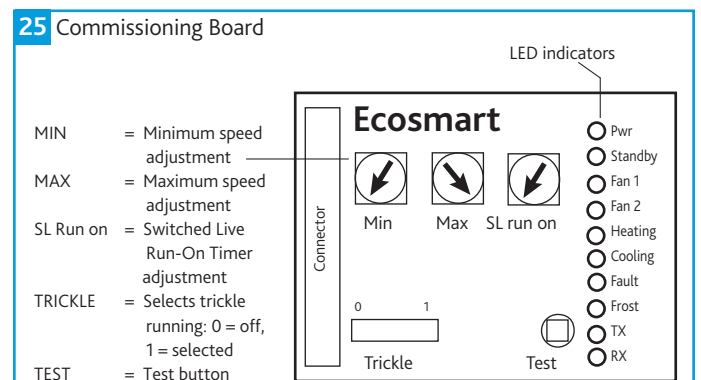

5.8 Wiring Diagrams for No (N) Control

The No (N) Control units described in this manual are supplied without any controls. It is the installer's responsibility to select and install suitable controller(s) and circuit(s) to produce the desired output from the units while remaining within the units safe performance envelope.

All electric heater control systems must include an over temperature safety device rated at 80°C maximum. The fans should remain running for at least 4 minutes after the electric element is turned off to ensure the unit does not overheat.

The wiring illustrations included below are for the fans, bypass damper and electric heater for units with No (N) Control. All wiring is terminated in junction boxes fitted to the specified side of the unit.

- Do not wire the power supply to motor via the motor alarm relay as terminals are only closed after the motor is energized.
- The alarm relay on condensate may require the use of a contactor if the host equipment supply is switched.

5.9 Wiring Diagrams for No (N) Control Units

5.9.1 Unit Sizes 10-15

26 Wiring - No Control - XBC10-15

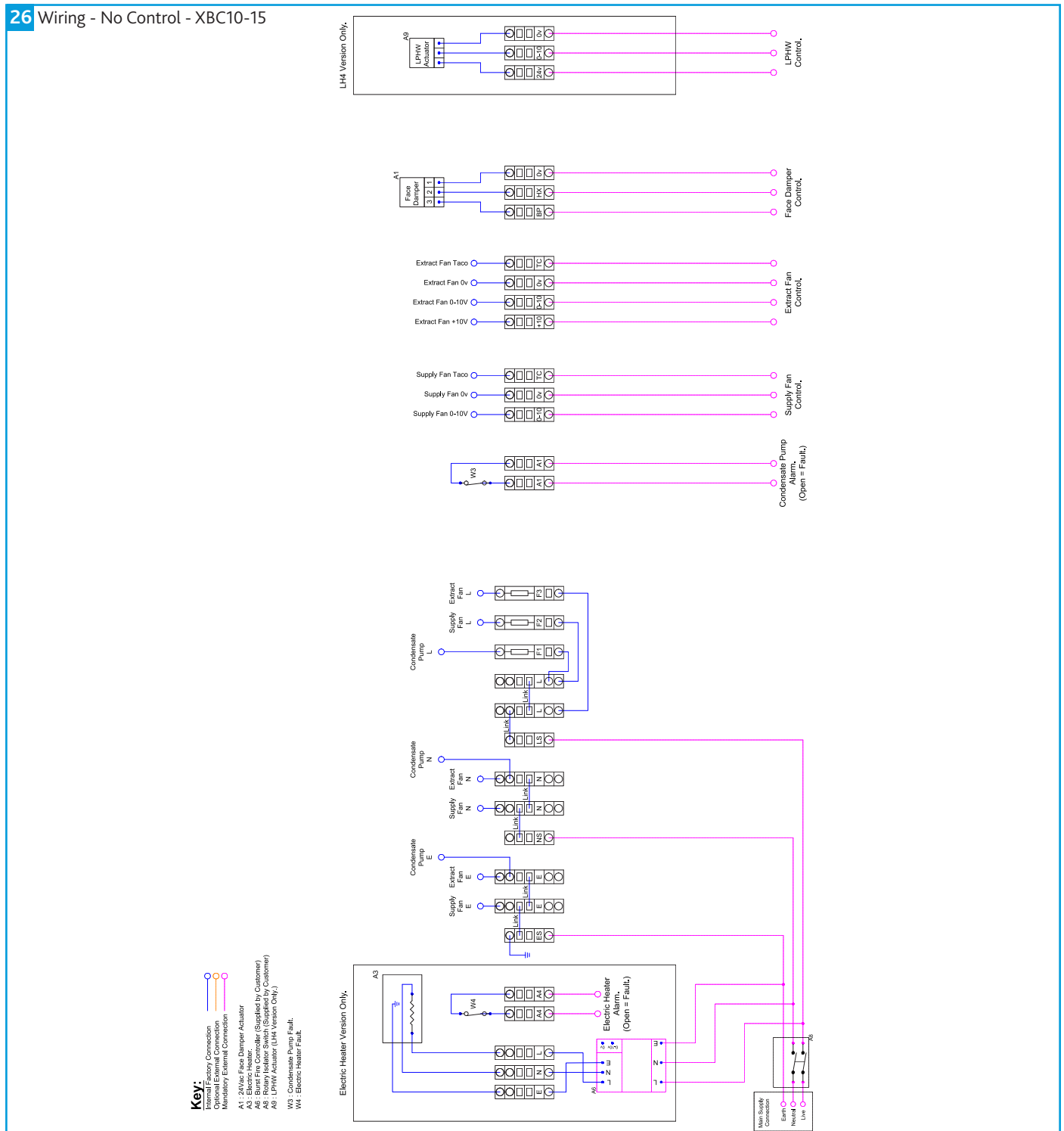

5.9.2 Unit Sizes 25-65

27 Wiring - No Control - XBC25-65

- Key:**
- Internal Factory Connection
 - External Factory Connection
 - Mandatory External Connection
 - External Connection
 - 24V Vac Face Damper Actuator
 - Electric Heater
 - Burst Fire Controller (Supplied by Customer)
 - Rotary Isolator Switch (Supplied by Customer)
 - LPHW Actuator (LH4 Version Only)
 - Supply Fan Alarm
 - Extract Fan Alarm
 - Condensate Pump Fault (not applicable to units with Enthality Heat Exchangers (XBE))
 - Electric Heater Fault (Electric Heater Version Only)

W3 : Condensate Pump Fault (not applicable to units with Enthality Heat Exchangers (XBE)).
 W4 : Electric Heater Fault (Electric Heater Version Only).

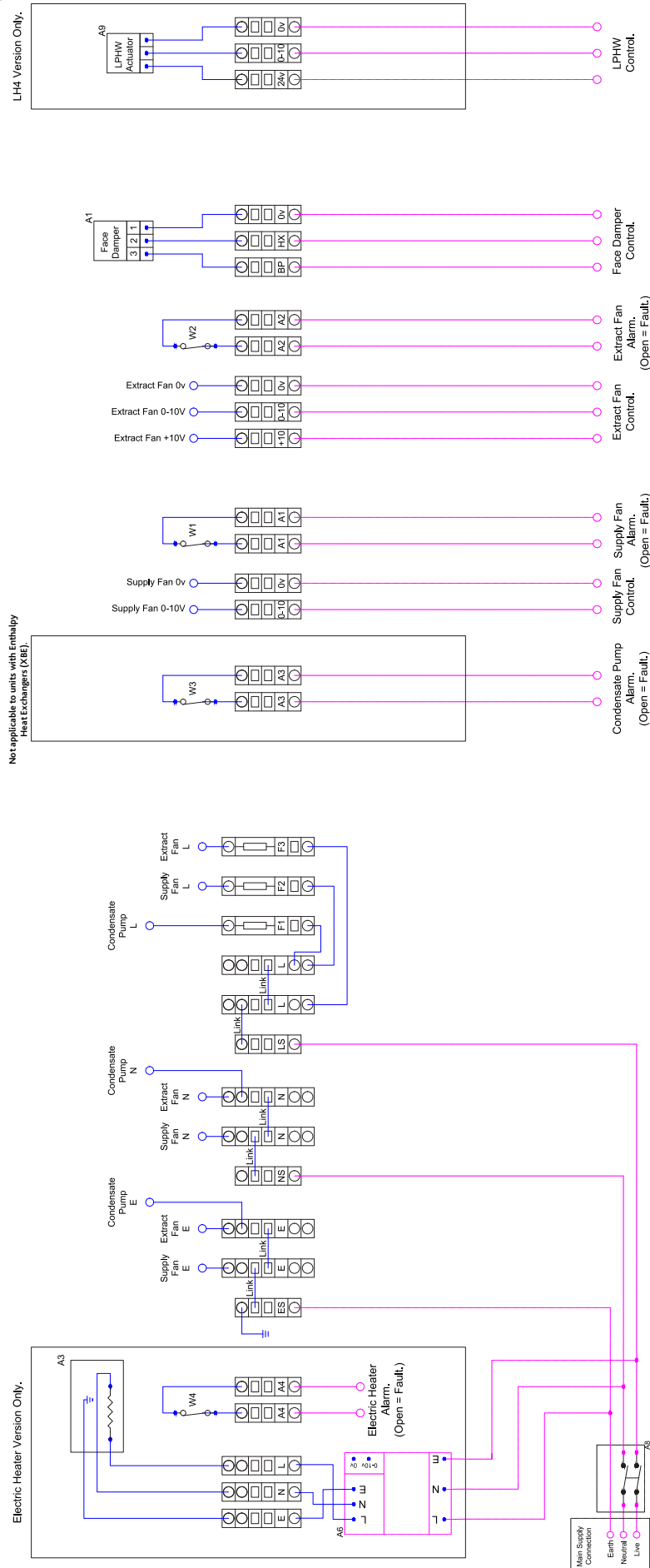

5.10 Wiring Diagrams for ES Control Units

5.10.1 Unit Sizes 10-15 with No Heating

28 Wiring - ES Control - XBC10-15 No Heating

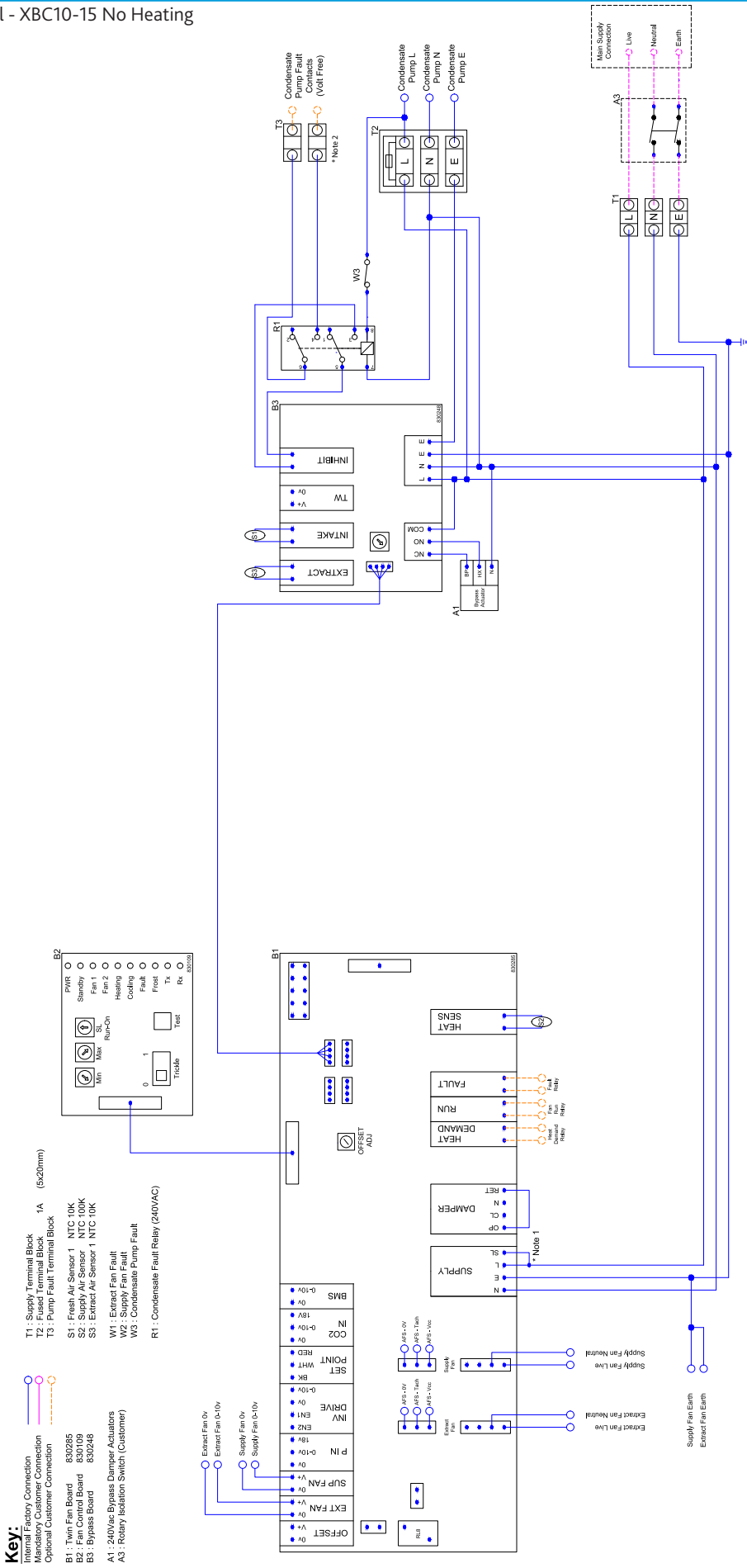

* Note 1 - Switch Live, Remove Link to switch live manually.
 * Note 2 - Condensate Pump Functions not applicable to units with Entalphy Heat Exchangers (X8E).

5.10.2 Unit Sizes 25-65 with No Heating

29 Wiring - ES Control - XBC25-65 with No Heating

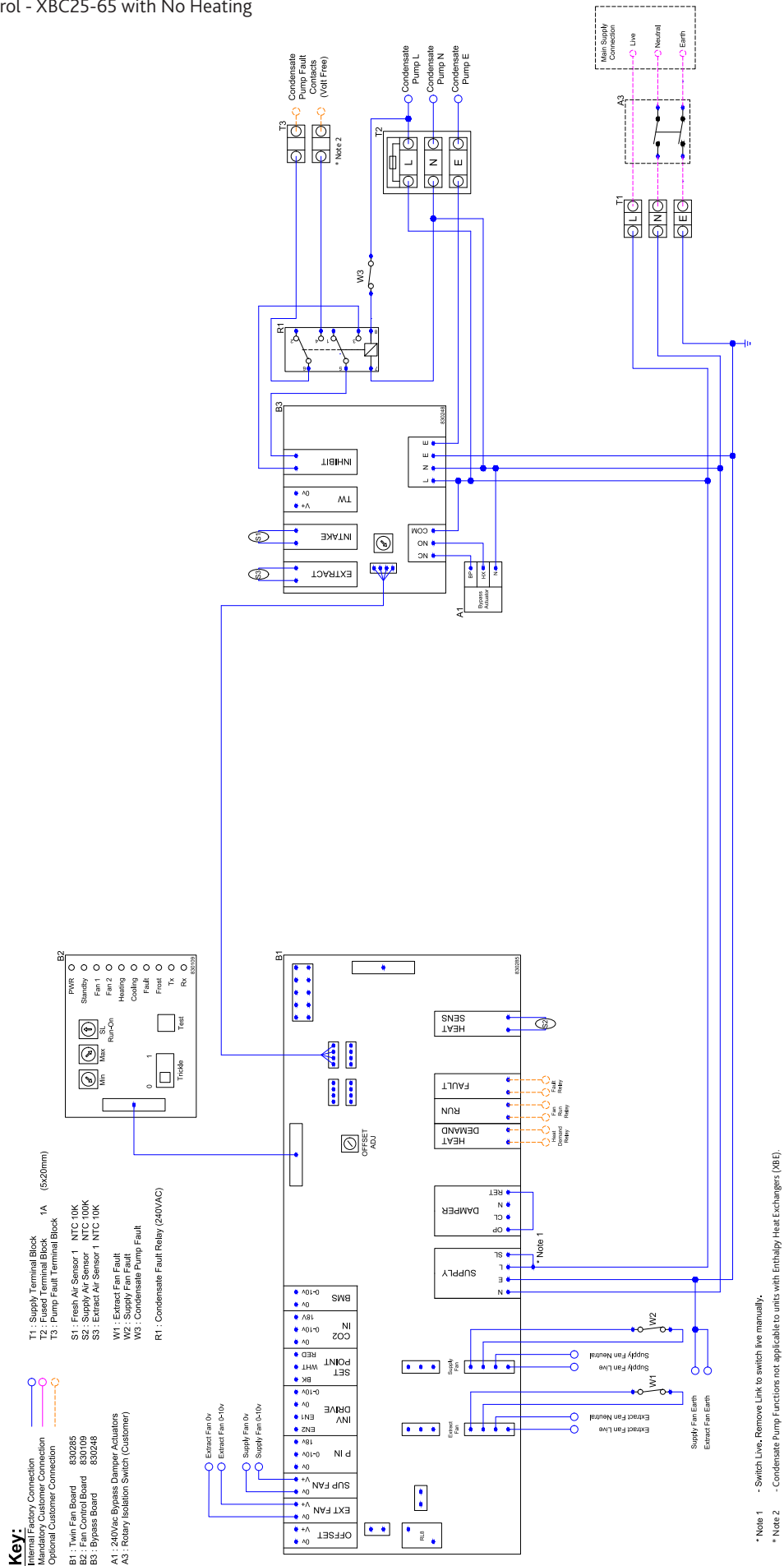

* Note 1 - Switch Live. Remove Link to switch live manually.
 * Note 2 - Condensate Pump Functions not applicable to units with Enthality Heat Exchangers (XBE).

5.10.3 Unit Sizes 10-15 with LPHW Heating

30 Wiring - ES Control - XBC10-15 with LPHW Heating

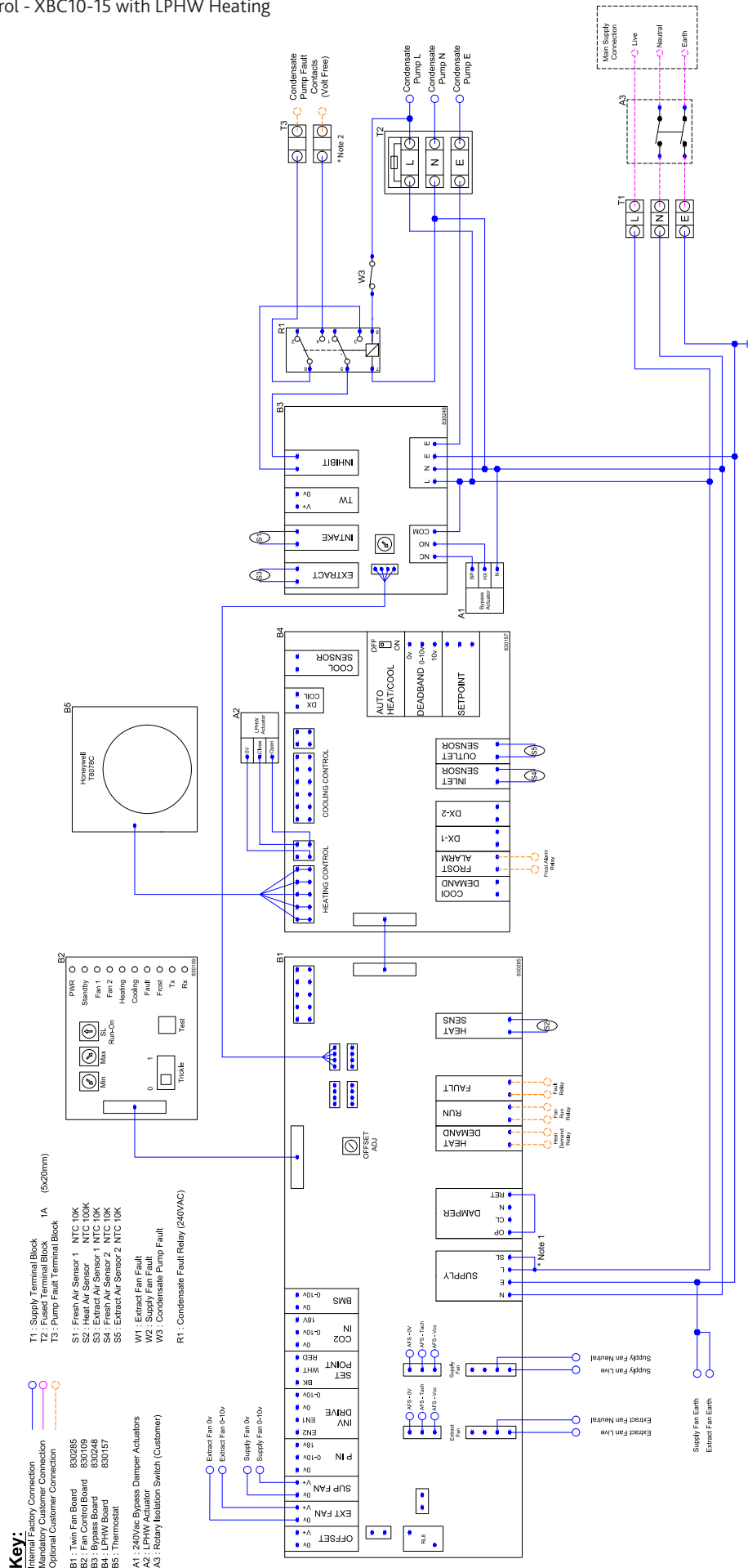

* Note 1 - Switch Live, Remove Link to switch live manually.
 * Note 2 - Condensate Pump Functions not applicable to units with Enthality Heat Exchangers (RE).

5.10.4 Unit Sizes 25-65 with LPHW Heating

31 Wiring - ES Control - XBC25-65 with LPHW Heating

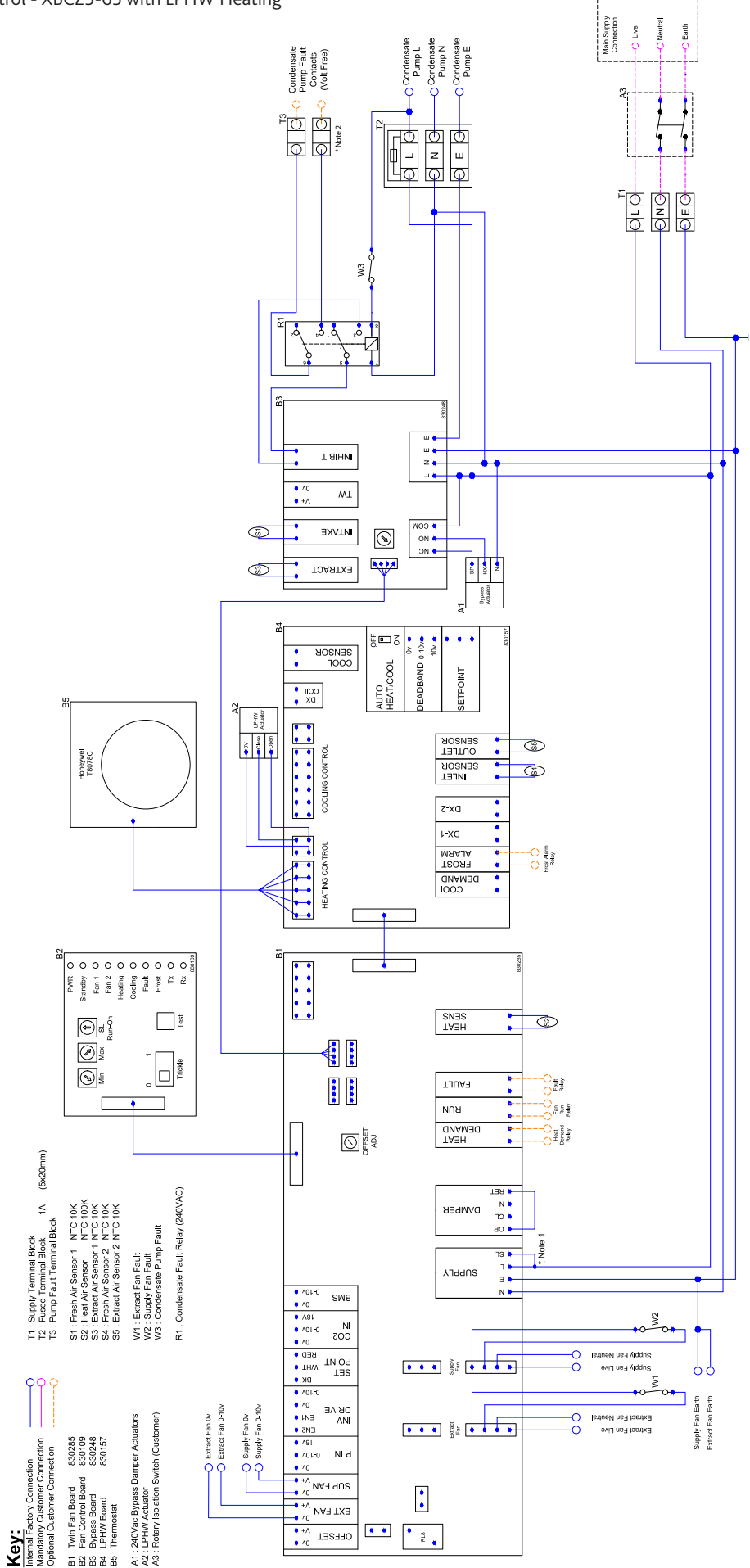

5.10.5 Unit Sizes 10-15 with Electric Heating

32 Wiring - ES Control - XBC10-15 with Electric Heating

Key:

- Internal Factory Connection
- Mandatory Customer Connection
- Optional Customer Connection

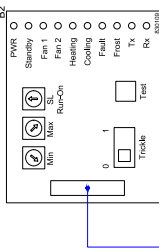

- T1 : Supply Terminal Block 1A (6x20mm)
- T2 : Fused Terminal Block
- T3 : Fused Terminal Block
- T4 : Electric Heater Supply Terminal Block
- S1 : Fresh Air Sensor 1 NTC 10K
- S2 : Heat Air Sensor NTC 100K
- S3 : Extract Air Sensor 1 NTC 10K
- W1 : Extract Fan Fault
- W2 : Supply Fan Fault
- W3 : Condensate Pump Fault
- W4 : Heater Fault
- R1 : Condensate Fault Relay
- R2 : Electric Heater Safety Latch Relay

- B1 : Twin Fan Board 830285
- B2 : Fan Control Board 830109
- B3 : Fan Control Board 830109
- B4 : LPHW Board 830157
- B5 : Thermostat
- A1 : 240V Acs Bypass Damper Actuators
- A2 : LPHW Actuator
- A3 : Rotary Isolation Switch (Customer)
- A4 : Electric Heater Controller
- A5 : Electric Heater

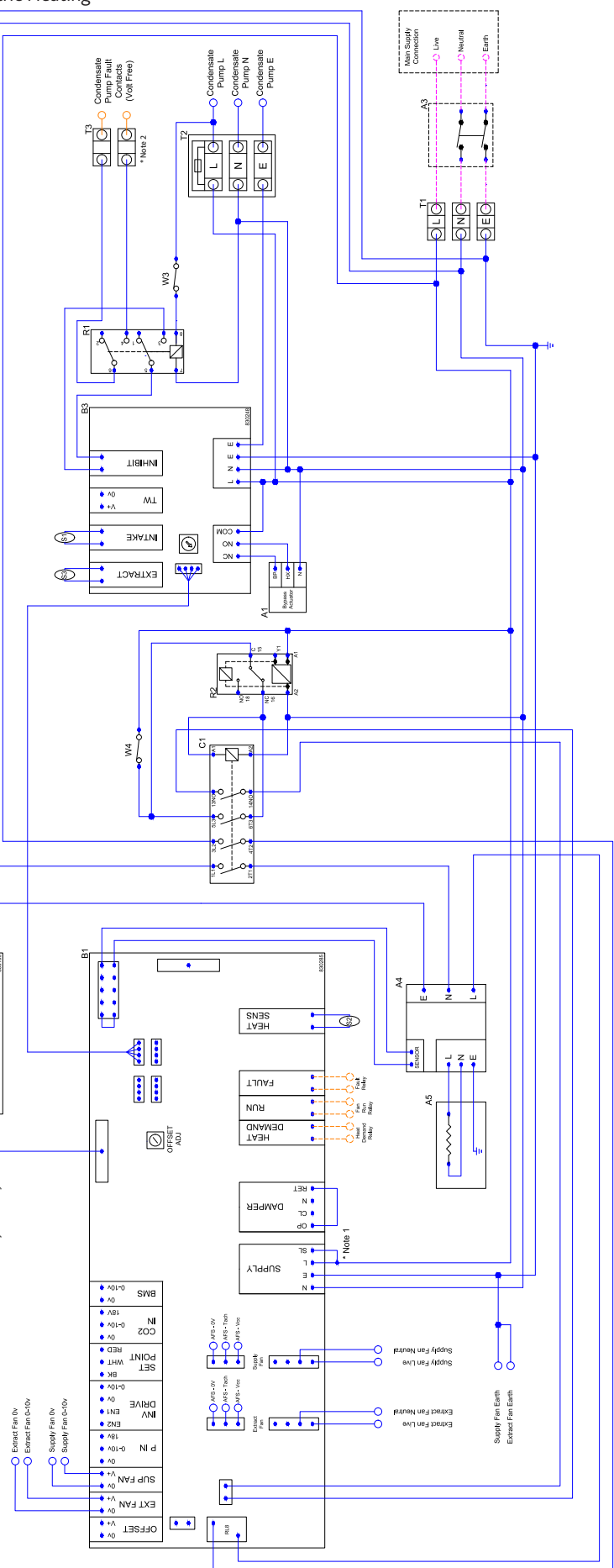

5.10.6 Unit Sizes 25-45 with Electric Heating

33 Wiring - ES Control - XBC25-45 with Electric Heating

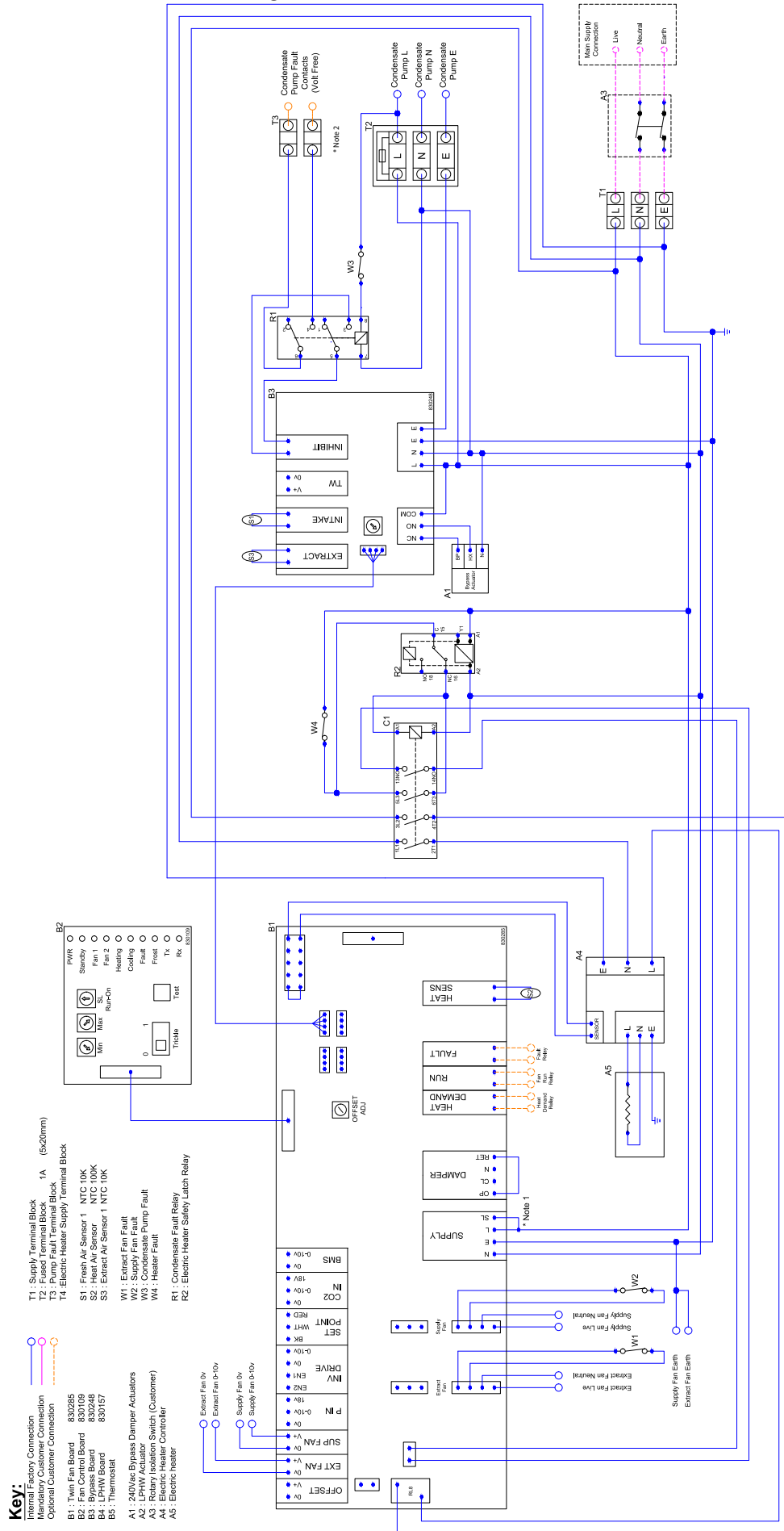

510.7 Unit Sizes 45-65 with Electric Heating

34 Wiring - ES Control - XBC45-65 with Electric Heating

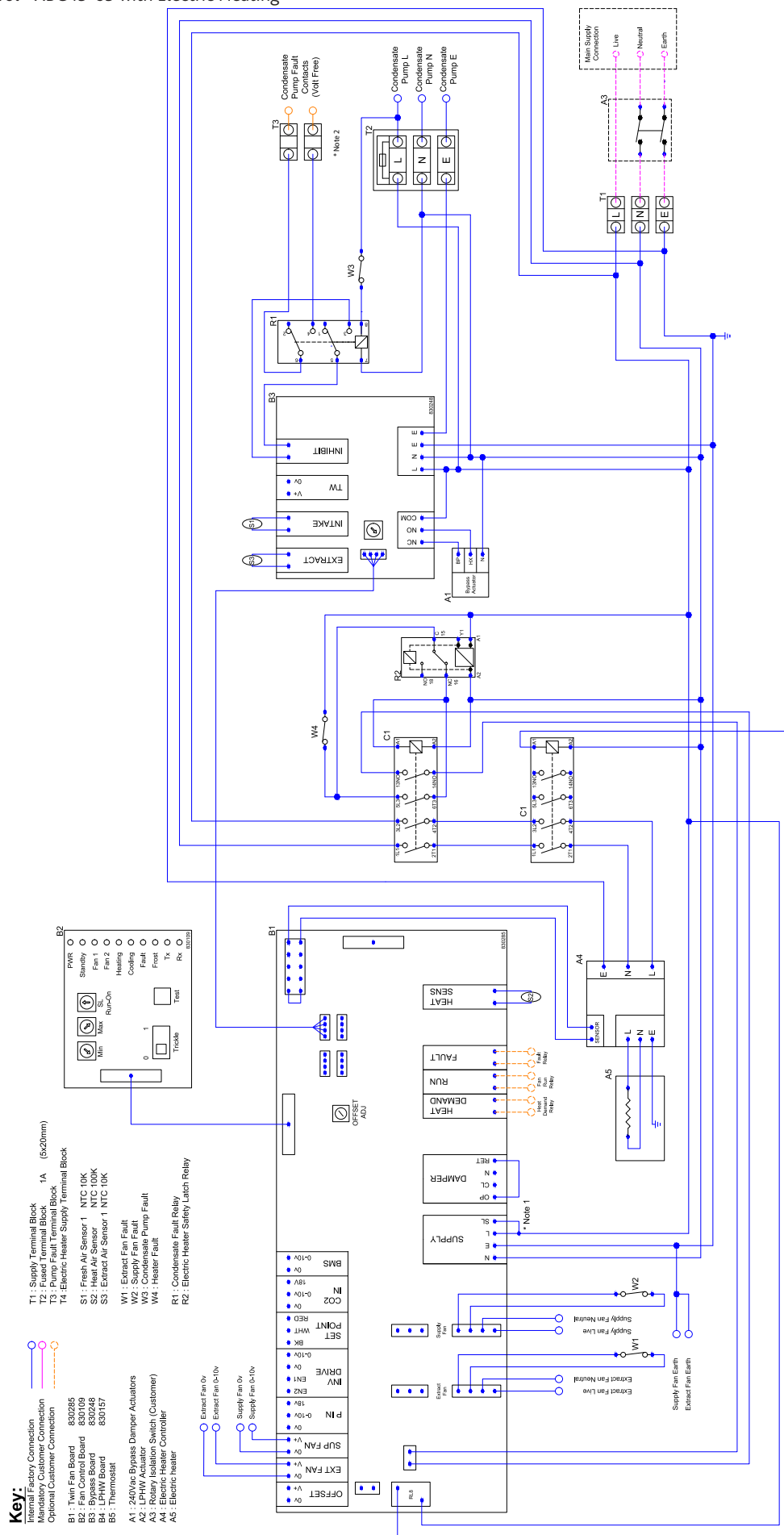

6.0 MAINTENANCE

It is important that maintenance checks are recorded and that the schedule is always adhered to, in all cases, the previous report should be referred to.

6.1 Routine Maintenance

- Clean all areas of unit and treat any areas of corrosion.
- Check all access doors for leakage and if necessary locks should be adjusted and any replacement gasket materials should be replaced as required.
- Any drain trays should be cleaned and repaired if necessary.

6.2 Every 3 Months

- Check filters and change/clean if required, failure to do so may impair the performance and energy efficiency of this unit.
- Ensure condensate drains are cleaned clear and that water can flow freely from unit.
- Check fin coil banks and heat exchangers. If necessary clean with a soft brush or vacuum. Check for signs of contamination.

6.3 Annually

- Thoroughly inspect the unit and its components for corrosion, acting immediately to treat/restore any damaged areas.
- All electrical terminals within the unit should be tightened.
- Check all earth connections.
- Check control damper blades.
- Check operation of damper actuators and linkages and adjust as necessary.
- Coil faces should be inspected and any dust removed.

7.0 WARRANTY

Ecosmart Classic (E) control units and Basic (N) control units with a standard finish have a 5 year and 2 year warranty respectively. Ecosmart Classic (E) control units and Basic (N) control units with a coastal (C4) unit finish have a 1 year warranty. The warranty starts from the day of delivery and includes parts and labour for the first year. The remaining period covers replacement parts only.

This warranty is void if the equipment is modified without authorisation, is incorrectly applied, misused, disassembled, or not installed, commissioned and maintained in accordance with the details contained in this manual and general good practice. **Failure to maintain the unit as recommended will invalidate the warranty.**

The product warranty applies to the UK mainland and in accordance with Clause 14 of our Conditions of Sale. Customers purchasing from outside of the UK should contact Nuaire International Sales office for further details.

8.0 END-OF-LIFE AND RECYCLING

Where possible Nuaire use components which can be largely recycled when the product reaches its end-of-life:

- Fans, motors, controls, actuators, cabling and other electrical components can be segregated into WEEE recycling streams.
- Sheet metal parts, aluminium extrusion, heating/cooling coils and other metallic items can be segregated and fully recycled.
- EPP, plastic ducting, nylon corner pieces, plastic heat exchangers, packaging material and other plastic components can be segregated into mixed plastic and widely recycled.
- Cardboard packaging, wood, used filters and other paper components can be largely recycled or fully processed in energy from waste centres.
- Remaining Items can be further segregated and processed in accordance with the zero waste hierarchy. Please call After Sales Support for further information on items not listed above.

Ensure that Nuaire product is made safe from any electrical / water / refrigerant supplies before dismantling commences. This work should only be undertaken by a qualified person in accordance with local authority regulations and guidelines, taking into account all site based risks.

9.0 AFTER SALES AND REPLACEMENT PARTS

For technical assistance or further product information, including spare parts and replacement components, please contact the After Sales Department.

If ordering spares please quote the serial number of the unit together with the part number, if the part number is not known please give a full description of the part required. The serial number will be found on the identification plate attached to the unit casing.

Telephone 02920 858 400
aftersales@nuaire.co.uk

Technical or commercial considerations may, from time to time, make it necessary to alter the design, performance and dimensions of equipment and the right is reserved to make such changes without prior notice.