



Ecosmart Connect (C) Control

Supply & Extract Ventilation with Heat Recovery

Installation Manual



1.0 SAFETY INFORMATION

- The provision of the electrical supply and the connection of the unit to the mains must be carried out by a qualified electrician.
- Isolate from power supply before removing any covers. During installation / maintenance ensure all covers are fitted before switching on the mains supply.
- All-pole disconnection from the mains as shown in the wiring diagram must be incorporated within the fixed wiring and shall have a minimum contact separation of 3mm in accordance with latest edition of the wiring regulations.
- This unit must be earthed.
- Ducting must be securely fixed with screws to the spigot to prevent access to live parts. Duct runs terminating close to the fan must be adequately protected by suitable guards.
- If the supply cord is damaged, it must be replaced by the manufacturer, its service agent or similarly qualified persons in order to avoid a hazard.
- Precautions must be taken to avoid the back-flow of gases into the room from the open flue of gas or other fuel-burning appliances.
- This appliance should not be used by children or persons with reduced physical, sensory or mental capabilities or lack of experience and knowledge, unless they have been given supervision or instruction concerning the safe use of the appliance by a person responsible for their safety. Children shall not play with the appliance. Cleaning and user maintenance shall not be carried out by children.

1.1 Symbols



GENERAL WARNING

Signifies a general warning regarding hazard specified by supplementary information.



ELECTRIC SHOCK

This unit must be completely electrically isolated before any panels are removed. Check mains supply and control connections.



ROTATING PARTS

This unit contains fast moving rotational parts which may start automatically. It is the sole responsibility of the installer to adequately guard these components.



REFER TO INSTRUCTION MANUAL

Read and understand the installation and maintenance manual before installing, operating or maintaining this product.

1.2 Important Information

This manual contains important information on the safe and appropriate assembly, transport, commissioning, operation, maintenance, disassembly and simple troubleshooting of the product.

While the product has been manufactured according to the accepted rules of current technology, there is still a danger of personal injury or damage to equipment if the following general safety instructions and the warnings contained in these instructions are not complied with.

- **Read these instructions completely and thoroughly before working with the product.**
- **Keep these instructions in a location where they are accessible to all users at all times.**
- **Always include the operating instructions when you pass the product on to third parties.**

1.3 Personal Protective Equipment

The following minimum Personal Protective Equipment (PPE) is recommended when interacting with Nuair product:

- **Protective Steel Toed Shoes** - when handling heavy objects.
- **Full Finger Gloves (Marigold PU800 or equivalent)** - when handling sheet metal components.
- **Semi Fingerless Gloves (Marigold PU3000 3DO or equivalent)** - when conducting light work on the unit requiring tactile dexterity.
- **Safety Glasses** - when conducting any cleaning/cutting operation or exchanging filters.
- **Reusable Half Mask Respirators** - when replacing filters which have been in contact with normal room or environmental air.

Nuair would always recommend a site specific risk assessment by a competent person to determine if any additional PPE is required.

2.0 INTRODUCTION

The information contained in this document provides details of installation, operation and maintenance for installers and users of the XBOXER XBC Supply and Extract Ventilation Unit with Heat Recovery.

This supply and extract air handling unit range comprises an combination of high efficiency centrifugal fans with EC motors, a Counterflow design plate heat exchanger, filters, optional heaters (LPHW and Electric) and a casing with high mass acoustic treatment.

A range of matched, close coupled attenuators with a similar construction method to that of the unit is available. The attenuators can be flipped for positioning on the left or right of the fan unit (Figure 1) allowing flexibility for duct layout.

Attenuators are available in 1050, 1250 and 1600mm lengths and a matching attenuator flange is attached to the fan unit.

General information regarding performance and specifications for the equipment may be obtained from our Technical Literature, and/or project specific documentation.

1 Unit Layout Overview

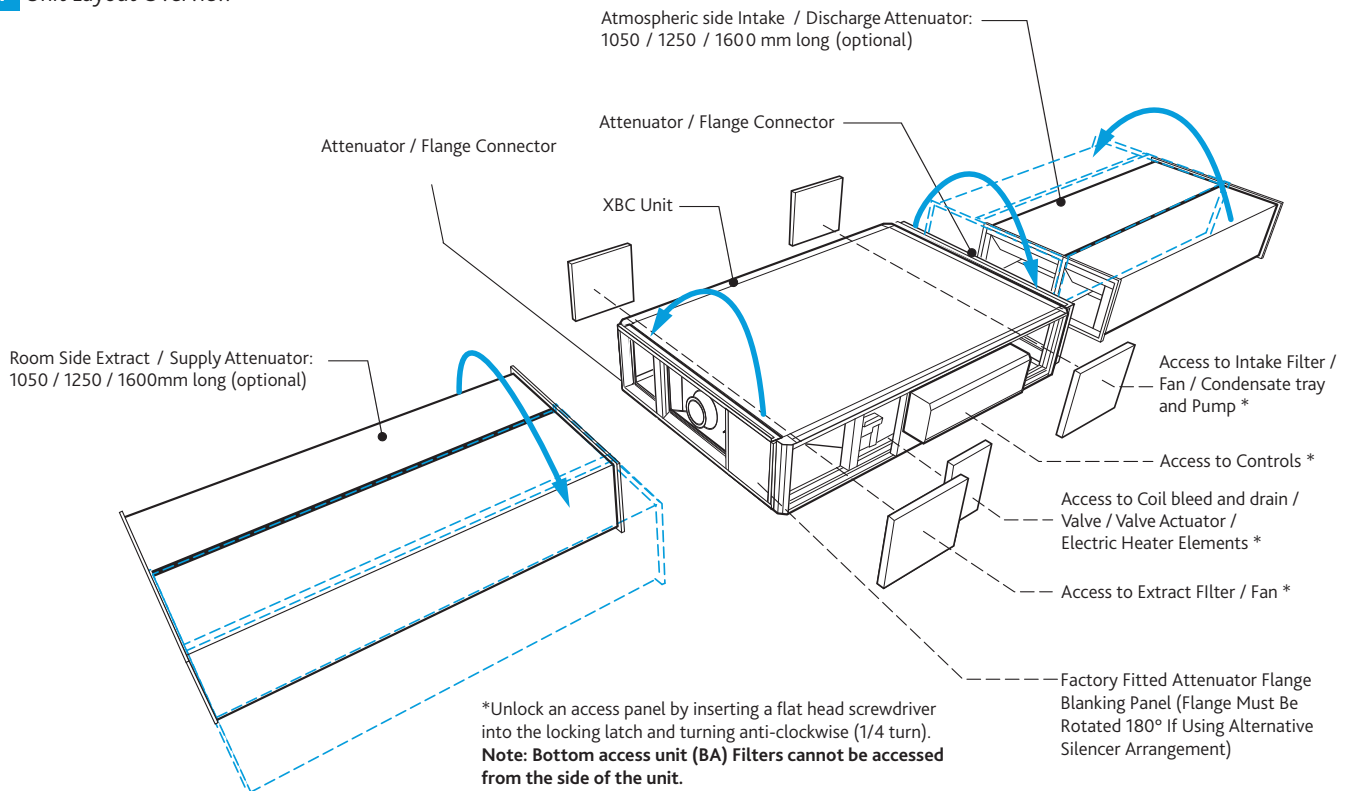

2.1 Code Description

| XB | C | 10 | H | A | - | L | H | 4 | - | C | P | L | S | 1 | S |
|----|---|----|---|---|---|---|---|---|---|---|----|----|----|----|----|
| 1 | 2 | 3 | 4 | 5 | - | 6 | 7 | 8 | - | 9 | 10 | 11 | 12 | 13 | 14 |

- 1. Range: **XBOXER**
- 2. HX Type: **C** = Counterflow
E = Enthalpy*
- 3. Unit Size: **10, 15, 25, 45, 55, 65**
- 4. Unit Layout: **H** = Horizontal
- 5. Filter Grade: **A** = G4 Supply & G4 Extract Panel Filters (Spare Included)
- 6. Heating Type: **E** = Electric
L = LPHW
N = No Heating
- 7. Heater Size: **H** = High Duty
L = Low Duty
N = No Duty
- 8. LPHW Valve Type: **4** = 4 Port Valve (3 Way With Bypass)
N = No Valve
- 9. Control Type: **C** = Ecosmart Connect Control
- 10. Constant Pressure Controls: **-** = Not Available
P = Constant Pressure
- 11. Controls Handing: **L** = Left Hand
R = Right Hand
- 12. Filter Access: **B** = Bottom Access
S = Side Access
- 13. Unit Finish: **1** = Standard
4 = Coastal (C4**)
- 14. Unit Roof: **S** = Standard Unit (No Roof)
W = Twin Pitched Roof (Factory Fitted)

*Enthalpy variants do not include a condensate pump or condensate connections. It is important to ensure that safe access is available to the control, filters and other accessible parts. Bottom access units are highly recommended for this type of application. Contact Nuairé for advice.

** This units coastal finish has been designed to withstand an External C4 Atmospheric Corrosivity Category as per BS EN ISO 12944-2:2017 providing that it is installed and maintained as per the manufacturer's instructions and general Warranty Guidance Notes found in our conditions of sale.

3.0 MECHANICAL INSTALLATION

Installation must be completed by competent persons, in accordance with good industry practice and should conform to all governing and statutory bodies i.e. IEE, CIBSE, etc.

3.1 Unit Access

In this product range, several unique concepts have been implemented with a view to simplifying the installation design. Nuairé recommend as best practice guidance, to allow for a minimum of around 600mm clearance. Whilst an absolute minimum access of 250mm is possible, access in this situation is difficult and does not allow for major maintenance including component replacement.

- 1. The unit configuration is such that the supply and discharge connections are positioned at the centre. The corresponding Intake and Extract connections may be positioned on either side of the unit, allowing greater flexibility in the layout of ductwork in the space, (Figure 4) with the blanking panel re-positioned to suit.

- 2. The right handed horizontal unit configuration is shown in Figure 6. With the light handed horizontal unit configuration shown in Figure 5.
- 3. With absolute minimum clearance, the unit may be connected to the power supply and control connections since the control may be rotated by 90 degrees to face downwards. (Cable connections must allow for the relative movement when the control is re-positioned). Filters may be changed and the fans coils, heat exchanger and condensate tray may be inspected and cleaned if necessary.
- 4. The LPHW and Electrical heater settings, coil bleed and drain, and all other control adjustments are similarly accessible (Figure 1).
- 5. Side access, where possible, is preferred in all cases in terms of safe working access to the equipment under the CDM regulations.
- 6. Where these arrangements are not suitable, the Consultant's and Contractor's project specific requirements will always be accommodated where possible.
- 7. Bottom access only units (Example code: XBC25HA-LH2-EPLB1S), provide access to filters only (Figure 7). Remove the filter covers on the front panel of the unit by gripping the two circular tabs either end of the filter covers and pulling away from the unit. The filter can now be extracted. Once the filters have been inspected return or replace them as necessary.

Filter removal is not available from the sides for bottom access units. Bottom access units must be installed with the following minimum clearance below the units. **XBC15 = 225mm, XBC25 = 300mm, XBC45 = 360mm, XBC55 = 480mm and XBC65 = 630mm.**

Unit is shipped with 4x G4 filters in place, 2 of which are included as spares. For higher grade replacement filters contact Nuairé. Pressure drops will vary with filter grade and this change in pressure must be accounted for when commissioning.

Unlocking an access panel is achieved by inserting a flat head screwdriver into the locking latch groove and turning anti-clockwise (1/4 turn), keys are neither required nor provided.

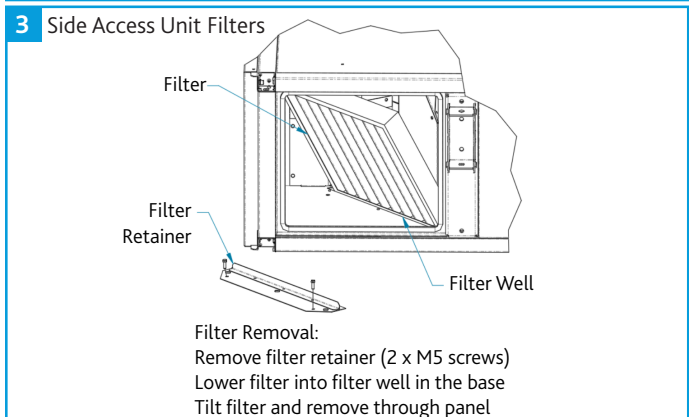
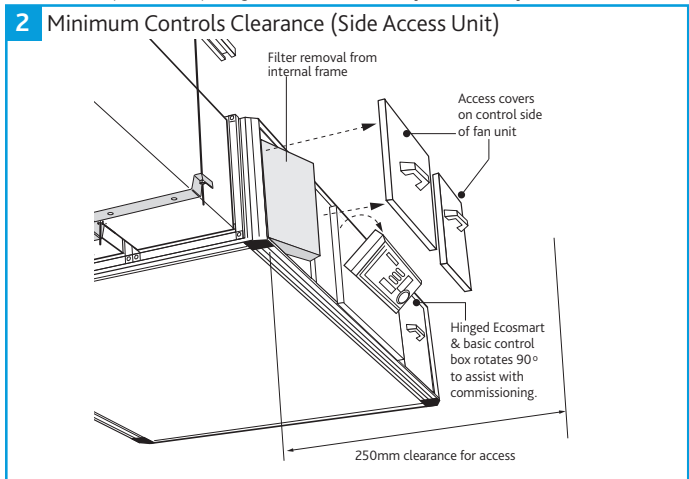

4 Selectable Duct Connections (Top View)

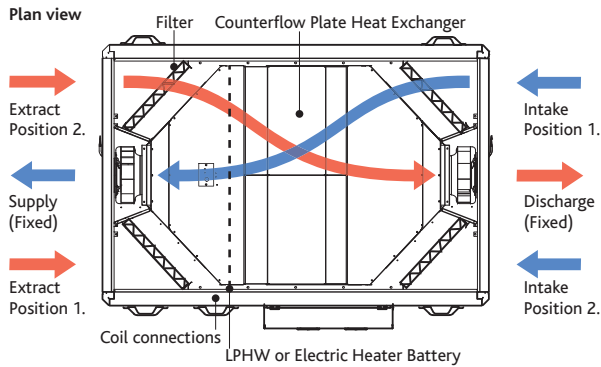

5 Left Handed (L) Arrangement (Top View)

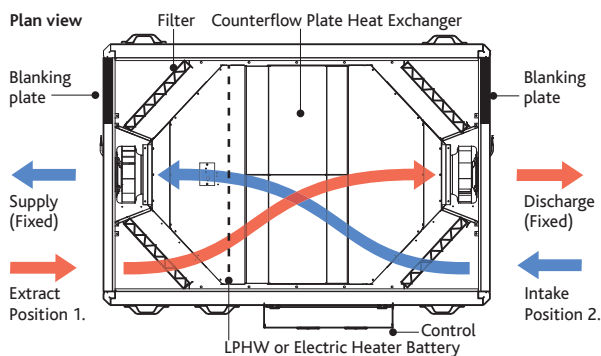

6 Right Handed (R) Arrangement (Top View)

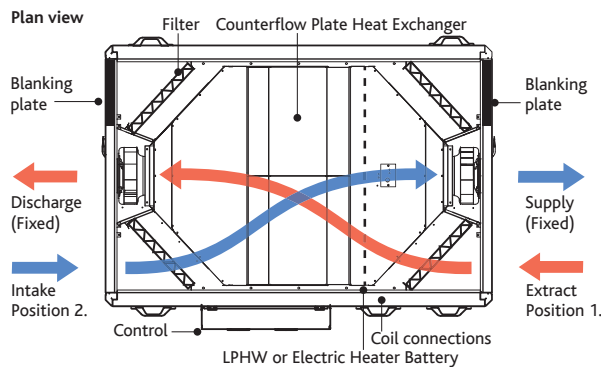

7 Bottom Access Unit Filters

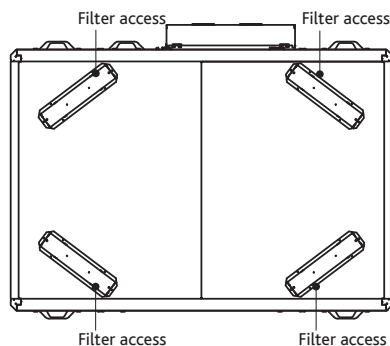

by the driver delivering the goods before offloading by the purchaser. No responsibility will be accepted for damage sustained during the offloading from the vehicle or on the site thereafter. All claims for damage and/or incomplete delivery must be reported to Nuair within two days of receipt of the equipment following Nuair's Terms & Conditions.

3.2.2 Offloading and Handling

The weight of the unit modules and palletised items is displayed on the unit rating plate or on the packaging. Some of the modules have an uneven weight distribution, and this will be indicated by labelling where appropriate. Ensure that lifting and handling equipment is adequately rated. Offloading and positioning of the equipment is the responsibility of the purchaser.

Spreaders should be used when lifting with slings to avoid damage to the casings. Care must be taken to ensure that slings are correctly positioned to avoid crushing and twisting of the unit castings.

Where channels and/or support frames are bolted to the underside of the unit casing, slings or fork-lift arms should be positioned to locate in the apertures in the channels. If lifting eyes have been supplied / fitted it is recommended that they are used.

XBOXER XBC units will be delivered to site in one section and will be labelled with the direction of air flow. The direction convention must be observed during assembly.

The unit may only be operated in its intended horizontal installation plane and must be fully levelled during installation (this is essential to ensure that condensate drains correctly).

See Section 3.5 for dimensions and weights.

8 Unit Lifting

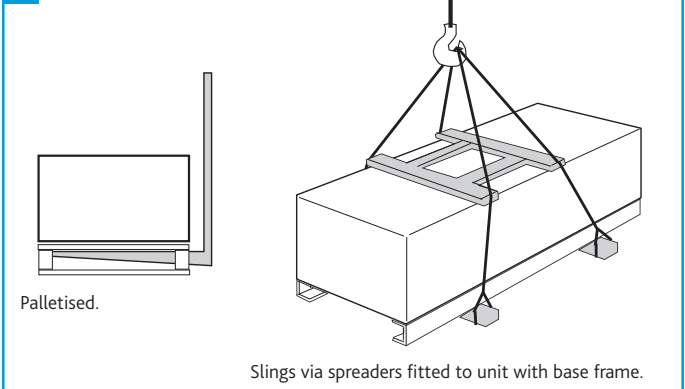

3.2.3 Storage

The equipment must be stored in a dry, internal location. Ductwork connection apertures shall be sealed against the ingress of dust, water and vermin. Do not stack units, modules or components.

Where fans are to be stored or bonded for extensive periods follow the Warranty Guidance Notes found in our conditions of sale.

3.3 Assembly of Equipment

Units must be installed in accordance with good industry practice.

These units may only be mounted horizontally and must be fully levelled in the horizontal plane. The units are heavy, and should be mounted using the fixing brackets supplied or other suitable methods of support. The supporting structure must be assessed for structural suitability.

Heat recovery components and modules that incorporate cooling coils may produce condensation during use. An insulated drip tray and condensate pump is provided. The drain connection must be connected to a suitable drainage point (Figure 22 on page 12 for details).

3.2 Delivery of Equipment

3.2.1 Receipt of Equipment

All equipment is inspected prior to despatch and leaves the factory in good condition. Upon receipt of the equipment an inspection should be made and any damage indicated on the delivery note.

Particulars of damage and/or incomplete delivery should be endorsed

3.4 Condensate Pump (Not Applicable To XBE Units)

3.4.1 Condensate Pump Alarm

The condensate pump incorporates an alarm function. If the water level in the condensate tray exceeds a maximum level (for example, as a result of the discharge tube becoming blocked or frozen), the alarm contact will open. This contact is internally connected to the heat exchanger bypass actuator, and the unit will automatically be placed into bypass mode, preventing further condensate production. Unit operation will otherwise be unaffected.

3.4.2 Condensate Pump Specification

Maximum flow rate = 12 l/h
 Maximum head = 20m Vertical, 100m Horizontal
 Pipe Connection size (Condensate) XBOXER XBC = 8 mm

LPHW Coils, if fitted, are tested during manufacture to 16 Bar (using dry compressed air). Coil and valve assemblies are similarly tested to 10 Bar. The operation of standard equipment is rated to PN6.

Electrical connections to the unit shall be made in accordance with the appropriate product and installation wiring diagrams provided, and shall use appropriately sized and rated cables.

Only the prepared apertures in the unit casing may be used for cable entry. Do not drill or cut the unit casing for this purpose. Cable access points are provided at the ends of the control enclosure.

If the control is rotated to aid connection of cables, please ensure that sufficient flexibility is provided in the final connection run.

To avoid conflict with the unit access panels, it is recommended that electrical and plumbing service connections to the unit are run at 90 degrees to the main air flow axis.

Control circuit connections must be segregated (i.e. routed separately) by a minimum of 50mm from power connections.

The unit rating label shows the maximum electrical load of the equipment. Connections to the unit may include single phase supply connections, and a variety of control circuits.

Only the prepared apertures in the unit casing may be used for cable entry. Do not drill or cut the unit casing for this purpose.

The equipment must be earthed and earth-bonded. Means of local isolation for maintenance purposes are generally required (by others). Ensure that all mains connections are isolated

3.5 Dimensions & Weights

9 Unit Dimensions & Weights

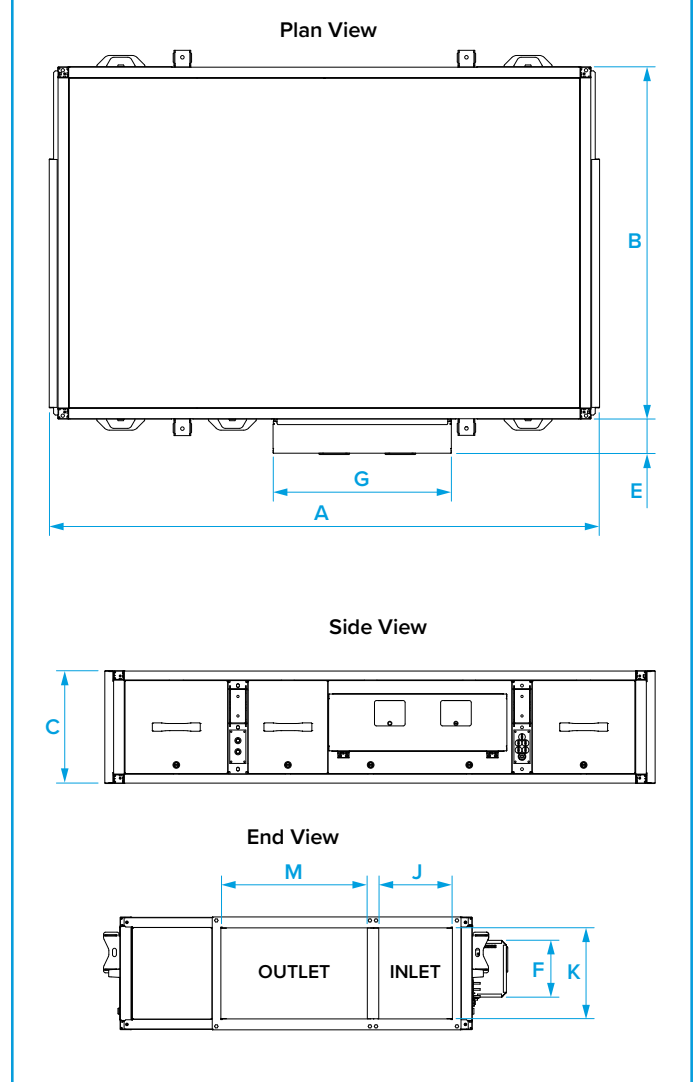

| Unit Code | Unit Dimensions (mm) | | | | | | Control Dimensions (mm) | | | Unit Weights | Packed Weights |
|-----------------|----------------------|------|-----|-----|-----|-----|-------------------------|-----|------|--------------|----------------|
| | A* | B | C | J | K | M | E | F | G | (kg) | (kg) |
| XBC10HA-***_*** | 1600 | 1000 | 260 | 238 | 220 | 347 | 130 | 210 | 640 | 195 | 261 |
| XBC10HA-***_**W | 1600† | 1210 | 335 | 238 | 220 | 347 | 210 | 230 | 674 | 217 | 283 |
| XBC15HA-***_*** | 1600 | 1000 | 260 | 238 | 220 | 347 | 130 | 210 | 640 | 195 | 261 |
| XBC15HA-***_**W | 1600† | 1210 | 335 | 238 | 220 | 347 | 210 | 230 | 674 | 217 | 283 |
| XBC25HA-***_*** | 1713 | 1160 | 340 | 252 | 302 | 471 | 130 | 210 | 640 | 242 | 308 |
| XBC25HA-***_**W | 1713† | 1390 | 426 | 252 | 302 | 471 | 276 | 287 | 820 | 267 | 333 |
| XBC45HA-***_*** | 1912 | 1262 | 400 | 270 | 360 | 531 | 130 | 210 | 640 | 298 | 405 |
| XBC45HA-***_**W | 1912† | 1490 | 487 | 270 | 360 | 531 | 276 | 287 | 954 | 328 | 435 |
| XBC55HA-***_*** | 1956 | 1562 | 472 | 397 | 430 | 587 | 130 | 210 | 640 | 375 | 546 |
| XBC55HA-***_**W | 1956† | 1562 | 571 | 397 | 430 | 587 | 215 | 386 | 1000 | 410 | 581 |
| XBC65HA-***_*** | 1913 | 1572 | 620 | 398 | 580 | 588 | 130 | 210 | 640 | 476 | 652 |
| XBC65HA-***_**W | 1913† | 1796 | 725 | 398 | 580 | 588 | 215 | 514 | 1000 | 514 | 690 |

† Excludes length of overhanging weatherproof roof.

3.6 Hanging Bracket Positions

10 Unit with Hanging Brackets Attached

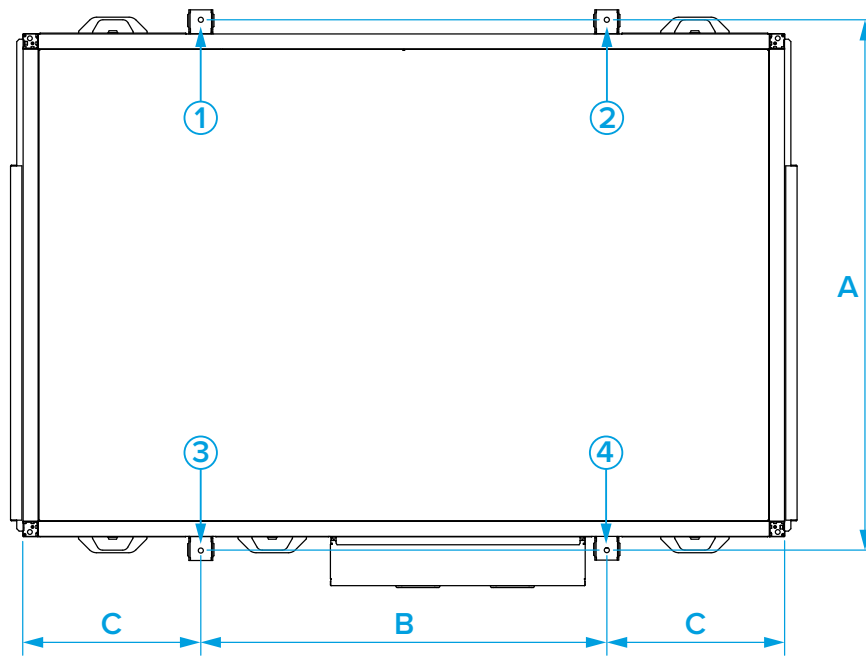

| Unit Code | Dimensions to Hole Centres (mm) | | |
|-----------------|---------------------------------|------|-----|
| | A | B | C |
| XBC10HA-***_*** | 1068 | 830 | 385 |
| XBC15HA-***_*** | 1068 | 830 | 385 |
| XBC25HA-***_*** | 1232 | 884 | 415 |
| XBC45HA-***_*** | 1332 | 1020 | 447 |
| XBC55HA-***_*** | 1632 | 1052 | 424 |
| XBC65HA-***_*** | 1644 | 1054 | 430 |

3.7 Flange Connector Dimensions (mm)

11 Flange Connector

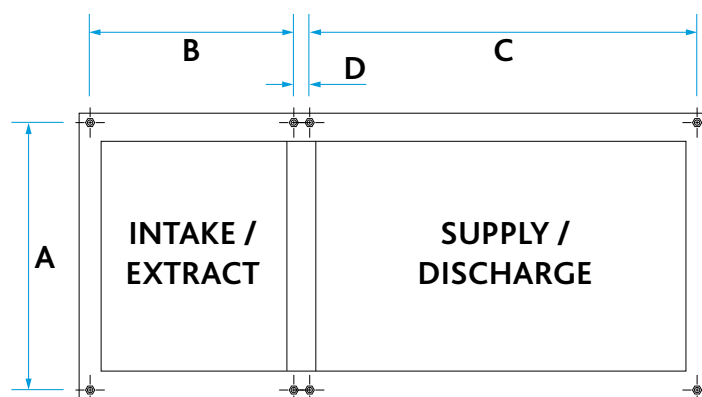

| Unit Code | Dimensions to Hole Centres (mm) | | | |
|-----------------|---------------------------------|-----|-----|----|
| | A | B | C | D |
| XBC10HA-***_*** | 240 | 258 | 367 | 22 |
| XBC15HA-***_*** | 240 | 258 | 367 | 22 |
| XBC25HA-***_*** | 322 | 273 | 491 | 22 |
| XBC45HA-***_*** | 380 | 291 | 552 | 22 |
| XBC55HA-***_*** | 450 | 418 | 608 | 22 |
| XBC65HA-***_*** | 600 | 418 | 608 | 22 |

3.8 Attenuator Dimensions & Weights

12 Attenuator Dimensions & Weights

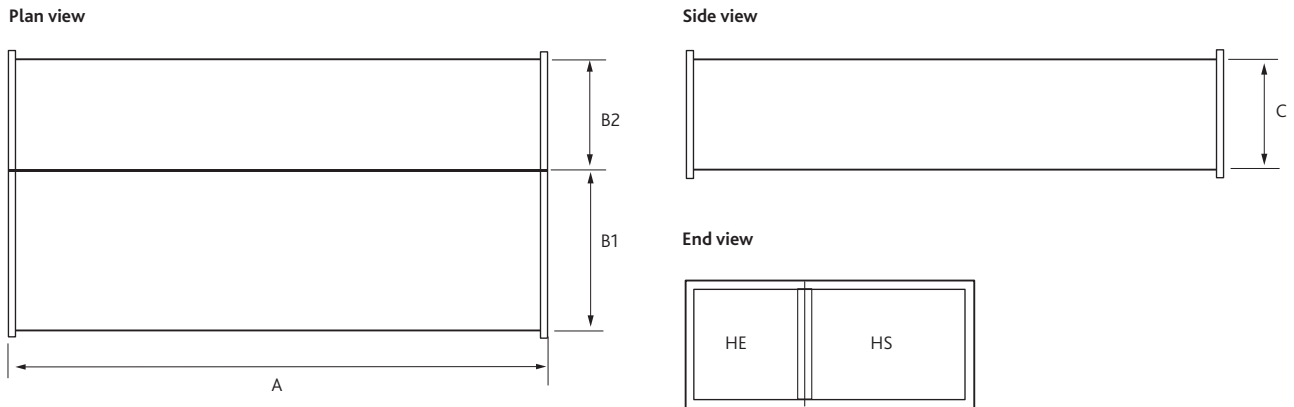

| Attenuator Code | Dimensions (mm) | | | | Attenuator Weights (kg) |
|-----------------|-----------------|-----|-----|-----|-------------------------|
| | A | B1 | B2 | C | |
| XBC15-HS-MS10* | 1050 | 347 | | 220 | 30 |
| XBC15-HE-MS10* | 1050 | | 238 | 220 | 24 |
| XBC15-HS-MS12* | 1250 | 347 | | 220 | 35 |
| XBC15-HE-MS12* | 1250 | | 238 | 220 | 29 |
| XBC15-HS-MS16* | 1600 | 347 | | 220 | 44 |
| XBC15-HE-MS16* | 1600 | | 238 | 220 | 36 |
| XBC25-HS-MS10* | 1050 | 471 | | 302 | 29 |
| XBC25-HE-MS10* | 1050 | | 252 | 302 | 29 |
| XBC25-HS-MS12* | 1250 | 471 | | 302 | 34 |
| XBC25-HE-MS12* | 1250 | | 252 | 302 | 34 |
| XBC25-HS-MS16* | 1600 | 471 | | 302 | 42 |
| XBC25-HE-MS16* | 1600 | | 252 | 302 | 42 |
| XBC45-HS-MS10* | 1050 | 531 | | 360 | 32 |
| XBC45-HE-MS10* | 1050 | | 270 | 360 | 32 |
| XBC45-HS-MS12* | 1250 | 531 | | 360 | 40 |
| XBC45-HE-MS12* | 1250 | | 270 | 360 | 37 |
| XBC45-HS-MS16* | 1600 | 531 | | 360 | 47 |
| XBC45-HE-MS16* | 1600 | | 270 | 360 | 47 |
| XBC55-HS-MS10* | 1050 | 588 | | 430 | 32 |
| XBC55-HE-MS10* | 1050 | | 398 | 430 | 36 |
| XBC55-HS-MS12* | 1250 | 588 | | 430 | 37 |
| XBC55-HE-MS12* | 1250 | | 398 | 430 | 42 |
| XBC55-HS-MS16* | 1600 | 588 | | 430 | 47 |
| XBC55-HE-MS16* | 1600 | | 398 | 430 | 52 |
| XBC65-HS-MS10* | 1050 | 588 | | 580 | 43 |
| XBC65-HE-MS10* | 1050 | | 398 | 580 | 46 |
| XBC65-HS-MS12* | 1250 | 588 | | 580 | 51 |
| XBC65-HE-MS12* | 1250 | | 398 | 580 | 54 |
| XBC65-HS-MS16* | 1600 | 588 | | 580 | 63 |
| XBC65-HE-MS16* | 1600 | | 398 | 580 | 67 |

2 attenuator flange connections are attached to every unit. Add 60mm to dimension 'A' to include both flanges for standard (no roof) units.

3.9 90° Bend Attenuator Dimensions & Weights

13 Attenuator Dimensions & Weights

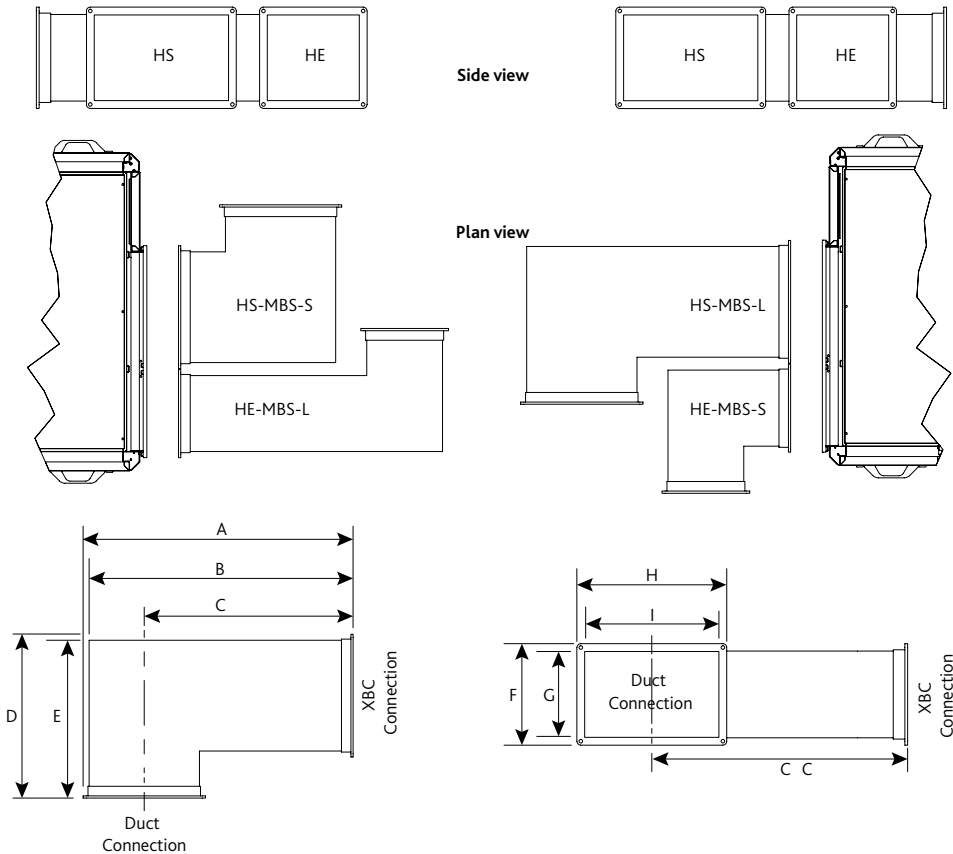

| Attenuator Code | Unit Dimensions (mm) | | | | | | | | | Attenuator Weights (kg) |
|-----------------|----------------------|------|------|-----|-----|-----|-----|-----|-----|-------------------------|
| | A | B | C | D | E | F | G | H | I | |
| XBC15-HS-MBS-S | 515 | 496 | 322 | 515 | 496 | 260 | 220 | 386 | 346 | 20 |
| XBC15-HS-MBS-L | 852 | 833 | 659 | 515 | 496 | 260 | 220 | 386 | 346 | 29 |
| XBC15-HE-MBS-S | 406 | 387 | 268 | 406 | 387 | 260 | 220 | 277 | 237 | 14 |
| XBC15-HE-MBS-L | 852 | 833 | 714 | 406 | 387 | 260 | 220 | 277 | 237 | 23 |
| XBC25-HS-MBS-S | 640 | 621 | 385 | 640 | 621 | 342 | 302 | 511 | 471 | 32 |
| XBC25-HS-MBS-L | 992 | 973 | 737 | 640 | 621 | 342 | 302 | 511 | 471 | 44 |
| XBC25-HE-MBS-S | 421 | 402 | 275 | 421 | 402 | 342 | 302 | 292 | 252 | 17 |
| XBC25-HE-MBS-L | 992 | 973 | 846 | 421 | 402 | 342 | 302 | 292 | 252 | 32 |
| XBC45-HS-MBS-S | 700 | 681 | 415 | 700 | 681 | 400 | 360 | 571 | 531 | 39 |
| XBC45-HS-MBS-L | 1070 | 1051 | 785 | 700 | 681 | 400 | 360 | 571 | 531 | 55 |
| XBC45-HE-MBS-S | 439 | 420 | 284 | 439 | 420 | 400 | 360 | 310 | 270 | 19 |
| XBC45-HE-MBS-L | 1070 | 1051 | 915 | 439 | 420 | 400 | 360 | 310 | 270 | 38 |
| XBC55-HS-MBS-S | 756 | 737 | 443 | 756 | 737 | 470 | 430 | 627 | 587 | 48 |
| XBC55-HS-MBS-L | 1253 | 1234 | 940 | 756 | 737 | 470 | 430 | 627 | 587 | 72 |
| XBC55-HE-MBS-S | 566 | 547 | 348 | 566 | 547 | 470 | 430 | 437 | 397 | 31 |
| XBC55-HE-MBS-L | 1253 | 1234 | 1035 | 566 | 547 | 470 | 430 | 437 | 397 | 58 |
| XBC65-HS-MBS-S | 756 | 737 | 443 | 756 | 737 | 620 | 580 | 627 | 587 | 54 |
| XBC65-HS-MBS-L | 1253 | 1234 | 940 | 756 | 737 | 620 | 580 | 627 | 587 | 82 |
| XBC65-HE-MBS-S | 566 | 547 | 348 | 566 | 547 | 620 | 580 | 437 | 397 | 36 |
| XBC65-HE-MBS-L | 1253 | 1234 | 1035 | 566 | 547 | 620 | 580 | 437 | 397 | 68 |

Coding:

HS - Denotes the type of silencer required for the supply or discharge.

HE - Denotes the type of silencer required for the extract or intake.

Note: XBC15 silencers are also suitable for XBC10 units.

3.10 Unit Installation

The ventilation unit must be installed first, with consideration made for the length of the associated attenuators.

Installation of these units, including all external services and controls should be performed in accordance with all appropriate site procedures, and MUST conform to all governing regulations e.g. CDM, CIBSE, IEE, and in strict accordance with the applicable Building Regulations.

The correct installation position for the units shall be decided with due regard to access and maintenance requirements, and the objective of minimising the system ductwork resistance.

The recommended installation method is to use standard Unistrut channel secured to the slab / steelwork above the unit.

Four suitable drop rods should be secured to the Unistrut channel and extended to be fixed to the unit's four mounting brackets, (two each side of the fan unit) or to other horizontal supports by others where wider load distribution is required.

3.11 Attenuator Installation

It is recommended that additional Unistrut channels are used to support the matched attenuators. M8 Drop rods should be secured to the Unistrut channel and extended to be fixed to the four piece support brackets to be used on the underside of the attenuators (Figure 15).

Note – once the attenuators are supported and levelled, and immediately before securing the attenuator to the attenuator flange connector, remove the backing from the Foam Sealing Strip.

The attenuators must be secured to the unit using the screws provided.

14 Unit Installation

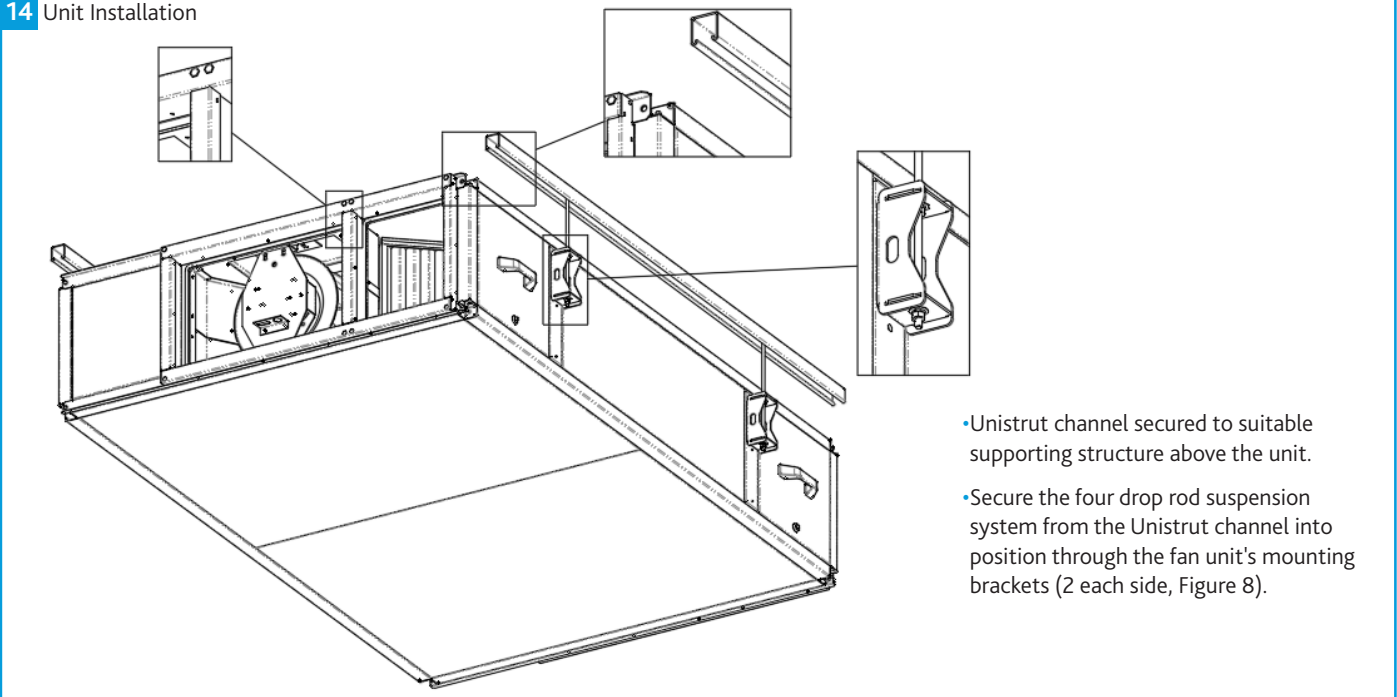

- Unistrut channel secured to suitable supporting structure above the unit.
- Secure the four drop rod suspension system from the Unistrut channel into position through the fan unit's mounting brackets (2 each side, Figure 8).

15 Attenuator Installation

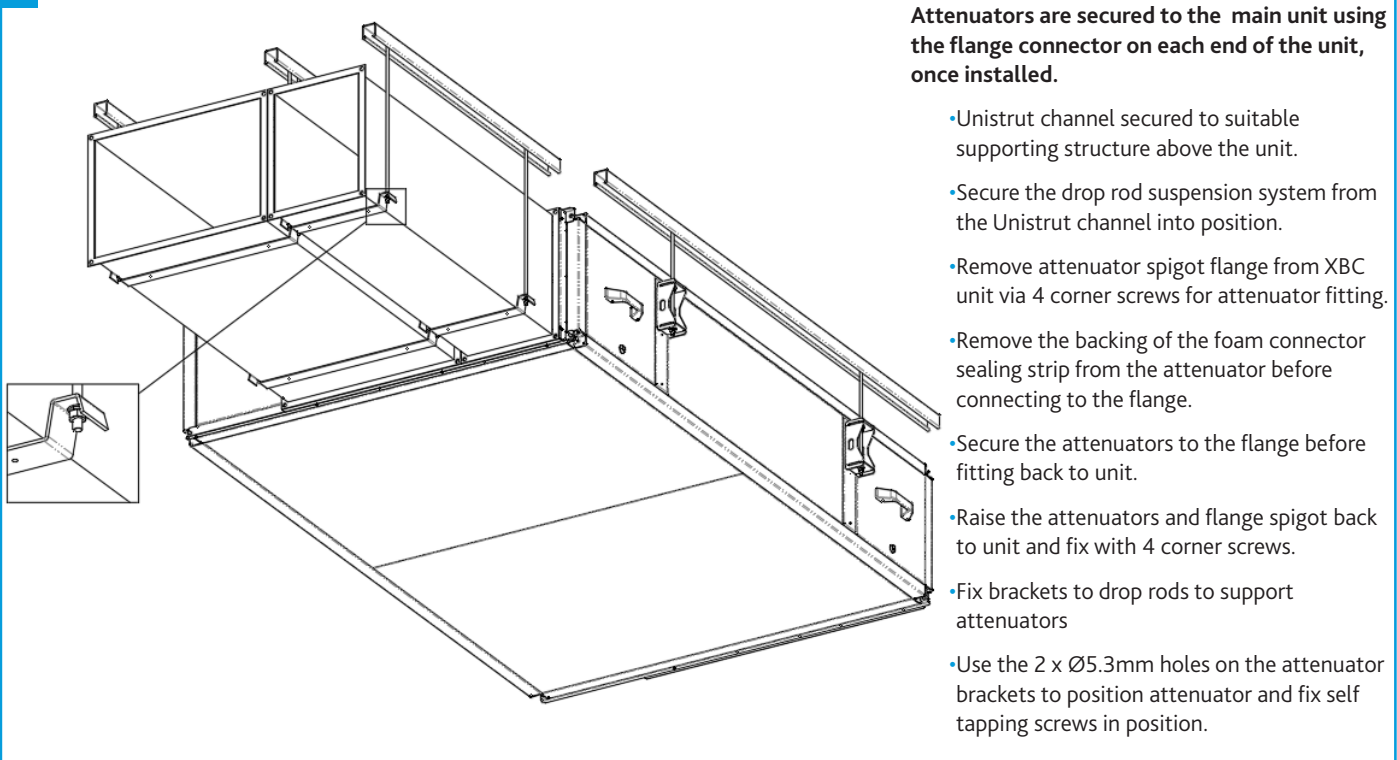

Attenuators are secured to the main unit using the flange connector on each end of the unit, once installed.

- Unistrut channel secured to suitable supporting structure above the unit.
- Secure the drop rod suspension system from the Unistrut channel into position.
- Remove attenuator spigot flange from XBC unit via 4 corner screws for attenuator fitting.
- Remove the backing of the foam connector sealing strip from the attenuator before connecting to the flange.
- Secure the attenuators to the flange before fitting back to unit.
- Raise the attenuators and flange spigot back to unit and fix with 4 corner screws.
- Fix brackets to drop rods to support attenuators
- Use the 2 x Ø5.3mm holes on the attenuator brackets to position attenuator and fix self tapping screws in position.

3.12 Weatherproof Kit Installation (If Supplied Separately)

Having installed the ventilation unit and attenuators, the Weatherproof Roof can now be installed if required.

The Roof assembly and control cover must be secured to the unit using the fixing channel provided.

When the roof has been installed onto the fan unit please ensure that the edges of the roof are fully sealed where it joins the fan unit. This does not apply to the control cover as this will have to be removed if necessary.

3.12.1 Weatherproof Kit Components

| Item | Description | Quantity |
|------|------------------------------|----------|
| A | Roof Assembly | 1 |
| B | Control Cover | 1 |
| C | Roof Fixing Bracket | 4 |
| D | Control Cover Fixing Channel | 2 |

3.12.2 Optional Exhaust & Intake Terminals

| Item | Description | Quantity |
|------|------------------|----------|
| E | Exhaust Terminal | 1 |
| F | Intake Terminal | 1 |

3.12.3 Terminal Part Codes

| Unit Size | Exhaust Terminal | Intake Terminal |
|-----------|------------------|-----------------|
| 10 | XBC10-EXHAUST-RT | XBC10-INTAKE-RT |
| 15 | XBC15-EXHAUST-RT | XBC15-INTAKE-RT |
| 25 | XBC25-EXHAUST-RT | XBC25-INTAKE-RT |
| 45 | XBC45-EXHAUST-RT | XBC45-INTAKE-RT |
| 55 | XBC55-EXHAUST-RT | XBC55-INTAKE-RT |
| 65 | XBC65-EXHAUST-RT | XBC65-INTAKE-RT |

16 Weatherproof Kit Installation

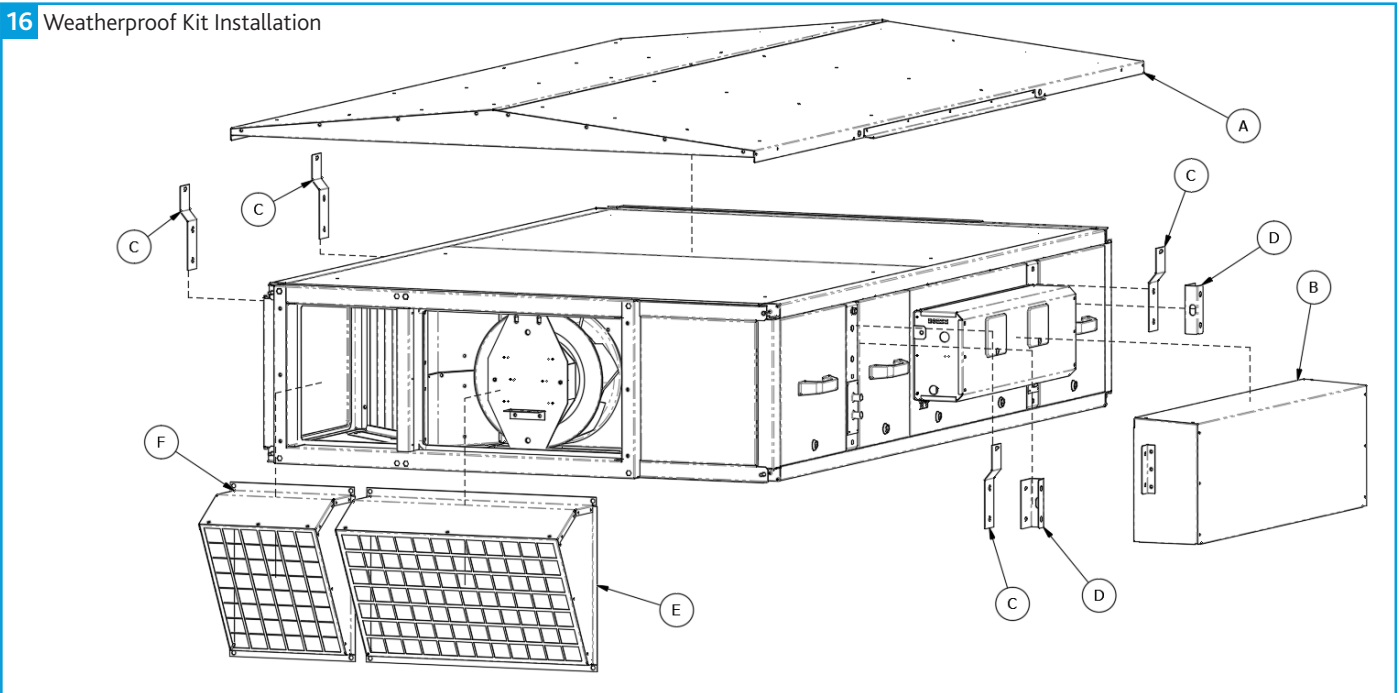

3.13 Motorised Dampers

If matched silencers of the same length (e.g. XBC15-HS-MS16 and XBC15-HE-MS16) are being fitted to the fan unit, the motorised damper (e.g. XBC15-MD-CO and XBC15-MD-CO-WP) should to be fitted after the silencers (Figure 17) to ensures that breakout noise levels are kept to a minimum.

Where unmatched silencers are being fitted to the fan unit, the motorised damper should to be fitted before the silencers.

The motorised damper units will be supplied loose and are designed to fit directly onto the flange connector (by others). The dampers feature fully interlocking parallel blades with a half inch diameter electroplated mild steel spindle. Nylatron bushes and external nylon/aluminium blade interconnection linkage. Fitted with Belimo SM24A-S open/close actuator complete with switch. Motorised damper wiring will require connection on site and possible extension of the cable looms.

17 Motorised Damper Installation

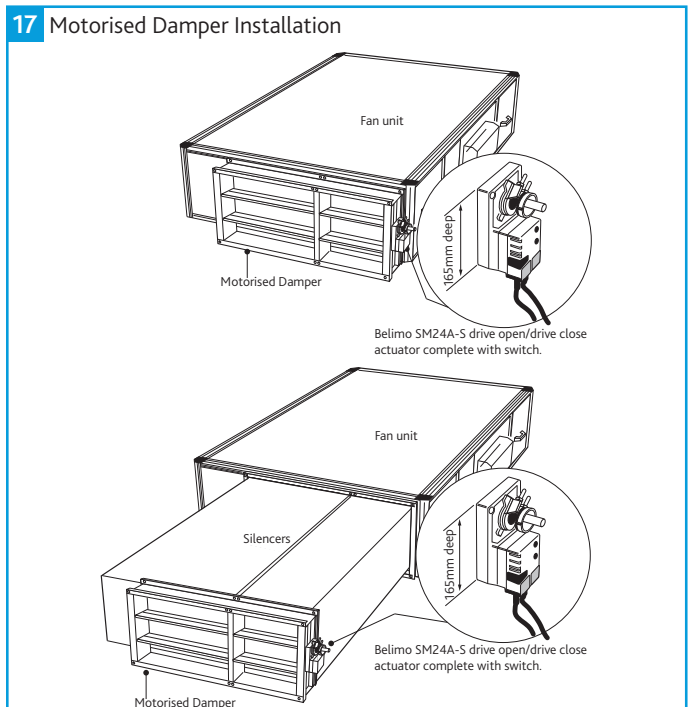

3.14 Constant Pressure (CP) Setup

Where applicable constant pressure sensors are supplied to control the static pressure at the extract fan inlet.

This set up is suitable for the majority of applications. When ancillaries with high pressure losses are fitted to the inlet side of the fan, the low pressure tapping must be moved from the fan chamber to a location upstream of the ancillaries, as shown below in Figure 18.

Failure to do this will result in excessive pressure being applied to the dampers at the rooms when the system is running in trickle mode.

3.15 Filter Pressure Switch

XBC units come with pre fitted pressure tappings for use with the dirty filter alarms (supplied loose) on both the supply and extract air streams. The IP54 pressure switch is equipped with a red visual LED alarm which will illuminate when the pressure reading surpasses that set by the adjustable knob.

3.15.1 Mounting Pressure Switch

Using the four mounting lugs provided, mount the pressure switches to a flat vertical surface using fixings appropriate for the surface. Any fixings used must have a maximum diameter of 8.0 mm. Do not tighten the fixings so much that the base of the device is deformed.

3.15.2 Connecting Pressure Tubing

Pressure tubing must not be kinked. Pay particular attention to this point if running hoses over an edge, it is better to form a loop.

For connection to the pressure switch, two fittings inherent in the housing are provided for hoses with an internal diameter of 6.0 mm.

- Connect a hose from the after filter (AF) pressure tapping to socket P1 which is located on the lower section of the housing.
- Connect a hose from the before filter (BF) pressure tapping to socket P2 which is located on the middle section of the housing.

After you have installed the hoses, it is essential to check them for tightness of fit at the connection points and to make sure that they run without any kinks.

3.15.3 Setting Switch Pressure

Make absolutely certain that there is no voltage on the electrical connections before you carry out any setting on the pressure switch, there is the possibility of an electric shock if you accidentally touch live parts.

Nuair recommend the pressure switch be set to trigger when the filters experience a 125 Pa increase above the clean filter resistance for the largest commissioned airflow rate. Use the adjustment dial to set the pressure at which the switch will trip. When the pressure falls below this set value, the switch returns to its resting position.

3.15.4 Switch Wiring

The cable gland is designed for cables with alternative sheath diameters of 7 mm or 10 mm. Only use these sizes. Otherwise the screw cable connection cannot seal adequately. The connections are intended for 6.3mm crimp-type sockets.

Remove switch cover. Wire the main unit to the terminal block within the switch as per the below wiring diagrams (Figure 18) ensuring the feed line is fused to suit Max 1.5A / 250 Vac. Refit switch cover.

18 Switch Wiring

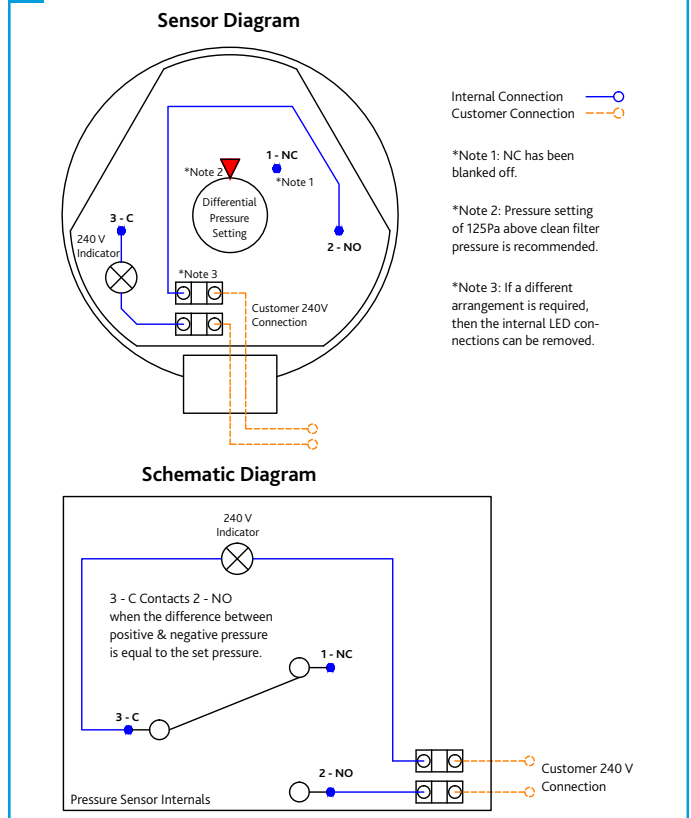

19 Constant Pressure Duct Tapping Locations

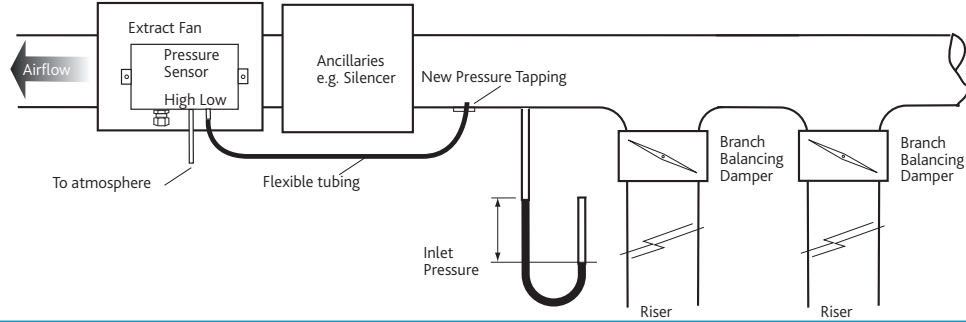

20 Pressure Tapping Layout (Left Hand Unit)

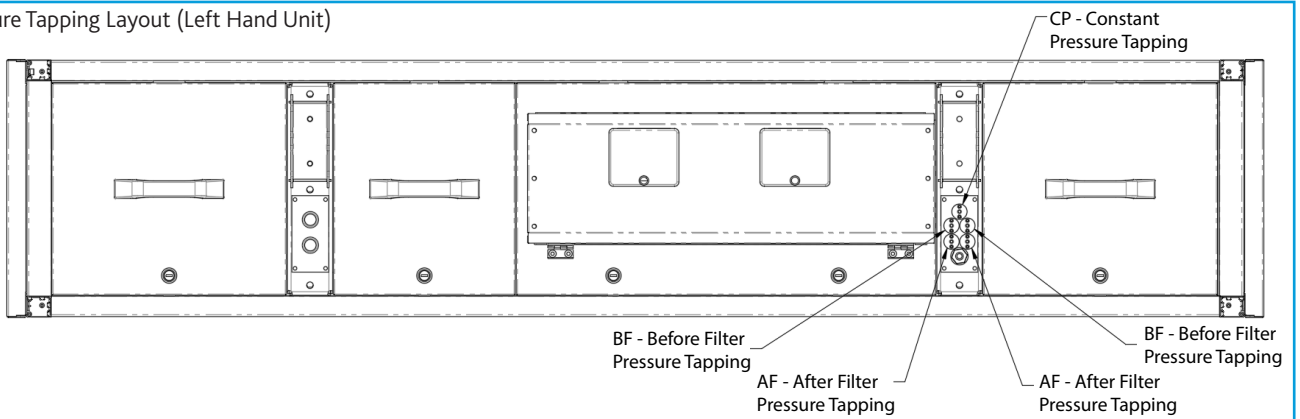

21 Pressure Tapping Layout (Right Hand Unit)

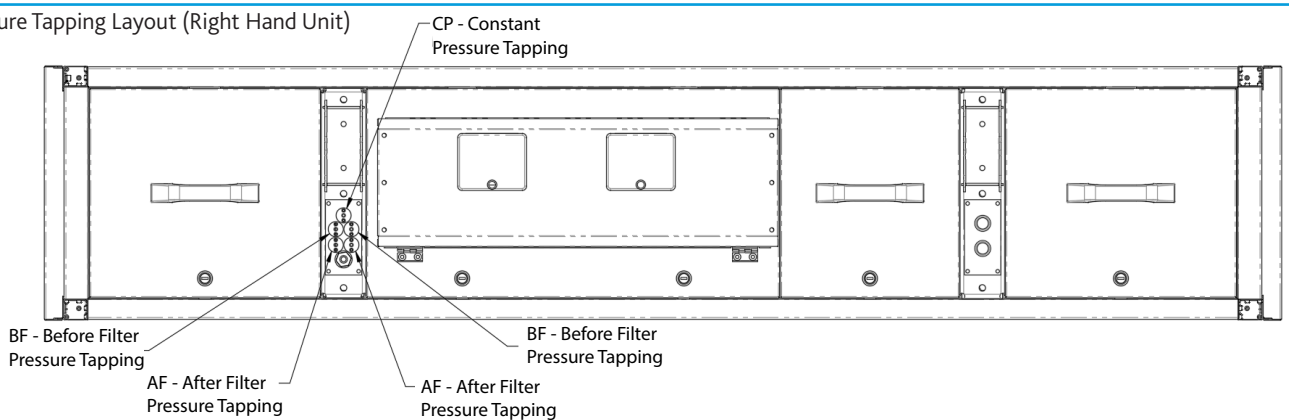

22 Coil & Condensate Drain Connections (Left Hand Unit)

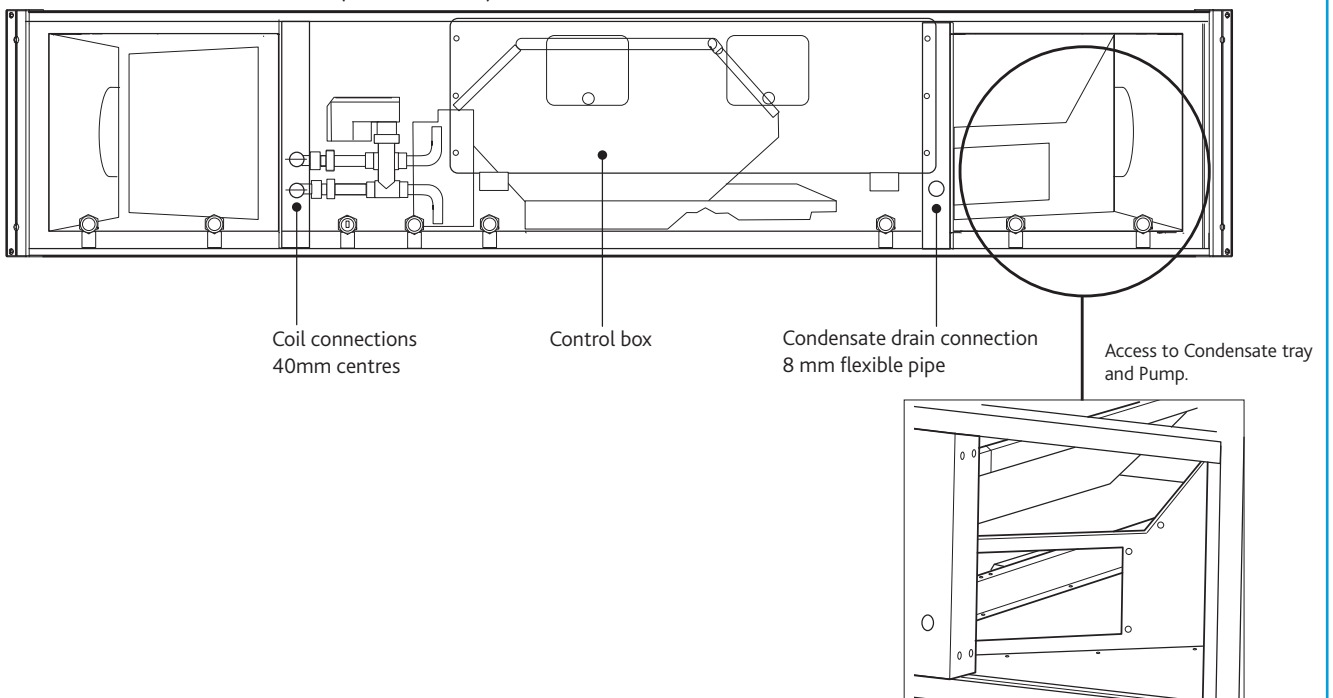

4.0 PRE-COMMISSIONING

Isolation - Before commencing work, make sure that the unit, switched live and Nuaire control are electrically isolated from the mains supply.

4.1 Filters

Remove filter access panels (observe and note airflow direction labels), inspect filters for contamination with construction debris, replace as necessary. Replace access panels.

Filter pressure drops will depend on actual flow rate and condition. Observe and record filter pressure drops after performance commissioning. Typically, filter "dirty" condition occurs when the initial filter "clean" readings have been increased by 125Pa.

If filter manometers, pressure switches or indicators have been fitted, they should be set or adjusted to reflect the commissioned system operation.

4.2 Heating Coils (LPHW)

Observe the Flow and Return connection labels on the unit. Drain and bleed valves are located on the coil. Other valves may be required in the system pipe-work depending on the installation (by others).

Where the wet system is at risk of frost damage, the addition of a proprietary anti-freeze solution to the water is recommended. Any frost protection offered by the unit's integral control system will not operate if the power supply to the unit is interrupted.

Frost protection is activated on any unit fitted with LPHW heating, when the outlet air temperature is 4°C or below. The unit reacts by shutting down the fan to prevent a 'wind chill' effect reducing the temperature to a point whereby the coil could freeze and burst. The unit will also drive open the LPHW valve to a fully open position to allow full water flow through the coil and the main PCB will close the 'Heat demand' contacts. These contacts could be used to send a signal to activate the boiler and/or valve to open to provide heat if not already doing so.

Piped connections should be made to the unit using appropriate techniques, and all pipework must be independently supported.

No hot work is permitted within one metre of the unit.

Ensure that installed pipework runs do not prevent or restrict access to the unit at any point.

The completed installation (including the connections within the unit, as these may be disturbed during installation) shall be pressure tested to the project engineer's specification (This is a condition of the unit warranty).

4.3 Fan Sections

Access to the fan section is via lift off panels (Figures 1 & 22).

With the unit electrically isolated, rotate the fan impeller / drive manually, checking that it spins freely. **Check all fixings are secure.**

Units must not be operated without all access panels in place – damage to equipment or injury to personnel may result. Units must not be operated unless control interlocks are in place – damage to equipment may result.

Test run motor for condition and correct rotation. Check that the correct current overloads are fitted and that the current being drawn does not exceed the motor nameplate value. Excessive current normally indicates that the ductwork system resistance is different to design.

5.0 ELECTRICAL INSTALLATION

The electrical wiring must be carried out by competent persons, in accordance with good industry practice and should conform to all governing and statutory bodies i.e. IEE, CIBSE, COHSE etc.

5.1 Electrical Supply

The control is powered by a 240Vac 50Hz supply. This must be isolated local to the unit and fitted with appropriate overcurrent and fault protection.

5.1.1 Electrical Supply Details - FLC

| Unit Without Electric Heater | | Unit With Electric Heater | | |
|------------------------------|-------|---------------------------|---------|--------|
| Unit Code | FLC | Unit Code | Fan FLC | Heater |
| XBC10HA-(N/L)** | 3.0 A | XBC10HA-E** | 3.0 A | 6.3 A |
| XBC15HA-(N/L)** | 4.0 A | XBC15HA-E** | 4.0 A | 12.5 A |
| XBC25HA-(N/L)** | 8.0 A | XBC25HA-E** | 8.0 A | 18.8 A |
| XBC45HA-(N/L)*** | 6.0 A | XBC45HA-E** | 6.0 A | 18.8 A |
| XBC55HA-(N/L)** | 6.0 A | XBC55HA-E** | 6.0 A | 37.5 A |
| XBC65-HA-(N/L)** | 6.0 A | XBC65HA-E** | 6.0 A | 37.5 A |

5.2 Volt Free Contacts

Note that the volt free contacts are not fused. If these are used to power any external equipment, the installer must provide adequate fusing or other protections.

Volt free relay contacts are rated at 3A resistive, 0.5A inductive.

Run Connections - Contacts closed when the fan is running

Fault Connections - No Fault = Contacts are closed

Fault - Contacts are opened

Heat Demand - Contacts closed when heating is selected.

Volt free versions of the switched live signals are also available at terminals T9-T10 & T11-T12. Link two contacts to activate the signal.

5.3 Damper Connections

A fan start delay can be imposed to allow the damper time to open. This is adjustable via display screens or commissioning tools.

If an I/O damper is fitted, it must be wired to the fan run relay, and the relay supplied with the relevant supply voltage.

See I/O Damper connection diagram for details.

5.4 Network Settings

Default MS/TP Address: 4
BACnet Instance Number: Randomised and unique for each controller (0 to 41164,304)

5.5 Connection Chart

| Description | Controller Terminal No | DI | AI | Relay Output | AO (0-10v) |
|-----------------------------------|------------------------|----|----|--------------|------------|
| Supply Fan Fault | IN1 | 1 | | | |
| Extract Fan Fault | IN2 | 1 | | | |
| IO Damper Alarm | IN3 | 1 | | | |
| Condensate Pump Fault | IN4 | 1 | | | |
| SL Enable | IN5 | 1 | | | |
| SL2 Input | IN6 | 1 | | | |
| EH Overtemp Fault (If Present) | IN7 | 1 | | | |
| Tacho Alarm Feedback (If Present) | IN8 | 1 | | | |
| Thermal Wheel Fault | IN11 | 1 | | | |
| Fresh Air Temp Sensor | IN13 | | 1 | | |
| Supply Air Temp Sensor | IN14 | | 1 | | |
| Return / Room Air Temp Sensor | IN15 | | 1 | | |
| Configurable Input 16 | IN16 | | 1 | | |
| Configurable Input 17 | IN17 | | 1 | | |
| Extract Fan Output | OUT1 | | | | 1 |
| Supply Fan Output | OUT2 | | | | 1 |
| Heating Output | OUT3 | | | | 1 |
| Cooling Output | OUT4 | | | | 1 |
| Bypass Damper Cmd | OUT6 | | | 1 | |
| Cooling Demand Cmd | OUT7 | | | 1 | |
| Heating / Recirc Cmd | OUT8 | | | 1 | |
| Fault Relay Cmd | OUT9 | | | 1 | |
| Fan Enable Cmd | OUT10 | | | 1 | |

5.6 Terminal Connections

5.6.1 Push In Termination

Stripped solid conductors, fine-stranded conductors with ferrules, or ultrasonically “bonded” conductors are simply pushed in until they hit the backstop, no tool is required.

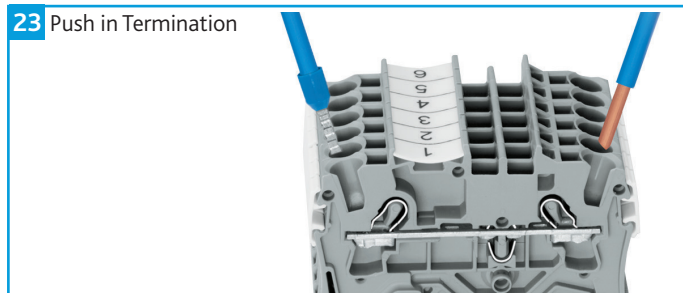

5.6.2 Termination Of Fine Stranded Conductors

Open the clamp by inserting an operating tool (as shown below) until it clicks into position. Then insert the conductor and remove the operating tool to complete the connection.

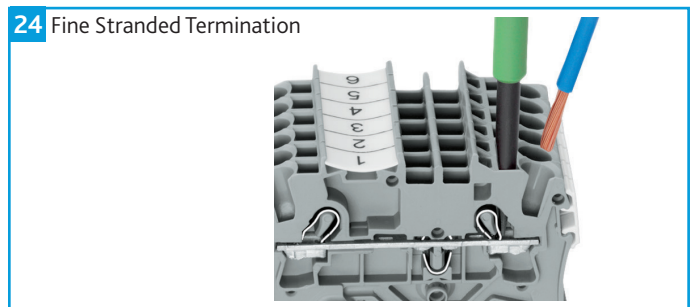

5.6.3 Conductor Removal

Insert an operating tool in to the operating slot to remove the conductor, just like the original CAGE CLAMP® terminals blocks.

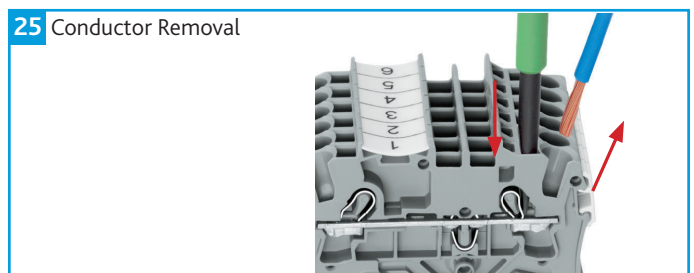

5.6.4 Fitting Jumpers

Terminal blocks can be connected together to increase the number of terminals at the same potential using push-in jumpers. In these cases the terminals are treated as one conductor.

26 Fitting Jumpers

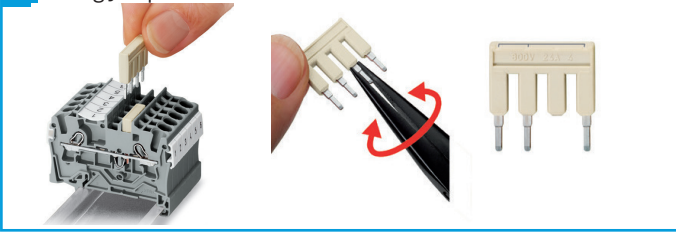

5.6.5 Jumper Removal

Insert the operating tool blade between the jumper and the partition wall of the dual jumper slots, then lift up the jumper.

27 Jumper Removal

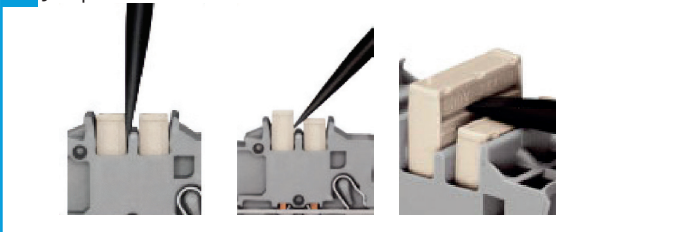

5.7 Unit Hardware Positions Diagram

28 Hardware Positions

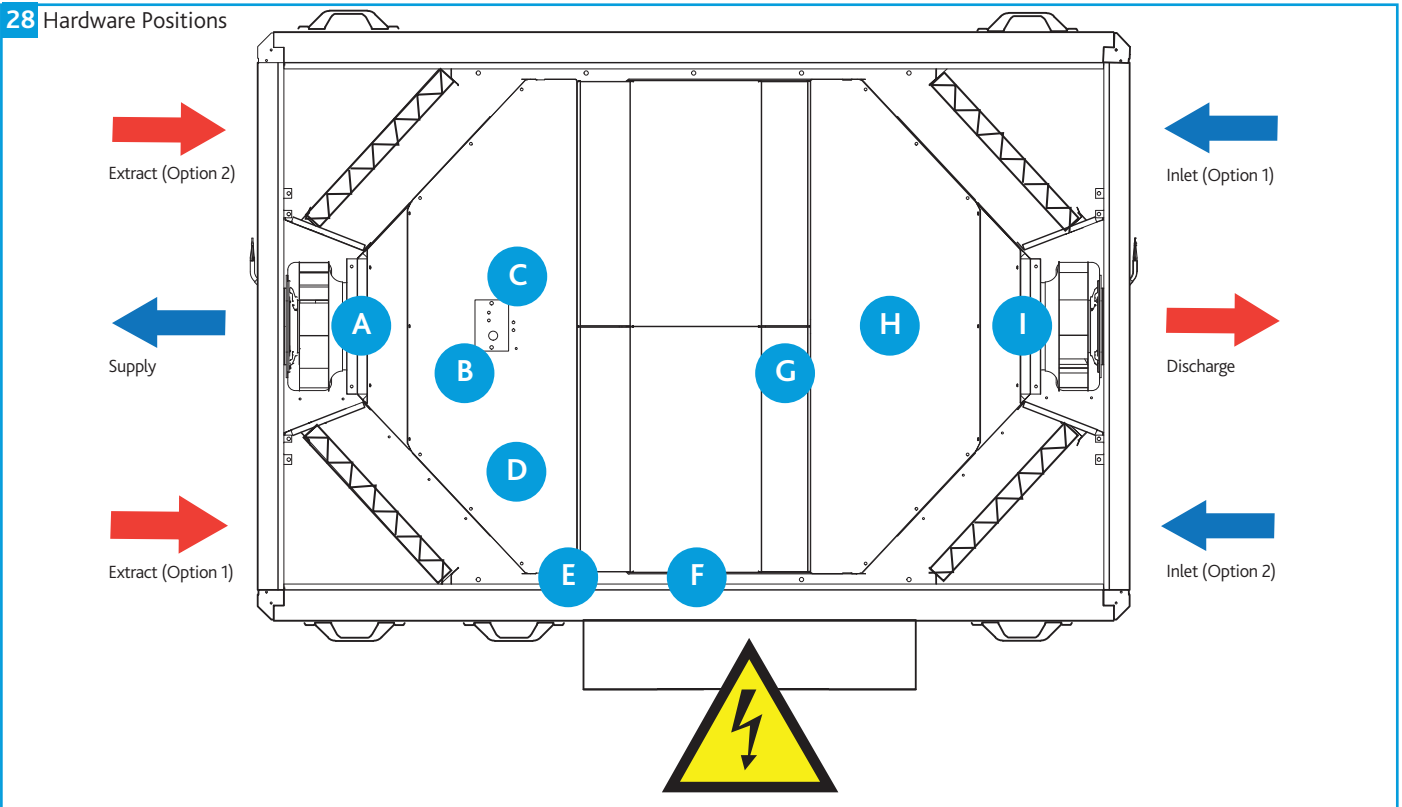

5.7.1 Hardware Position Key

- | | | |
|---|--|-----------------------------------|
| A) Supply fan (drive & health) | B) Delivery air temperature sensor | C) Extract air temperature sensor |
| D) Re-heater trip (electric heater models only) | E) LPHW re-heat drive (LPHW models only) | F) Bypass damper drive |
| G) Condensate pump alarm | H) Fresh air temperature | I) Extract fan (drive & health) |

5.8 Wiring Diagrams

5.8.1 XBC10-15 Units with No / LPHW Heating

29 Wiring - XBC10-15 Units with No / LPHW Heating

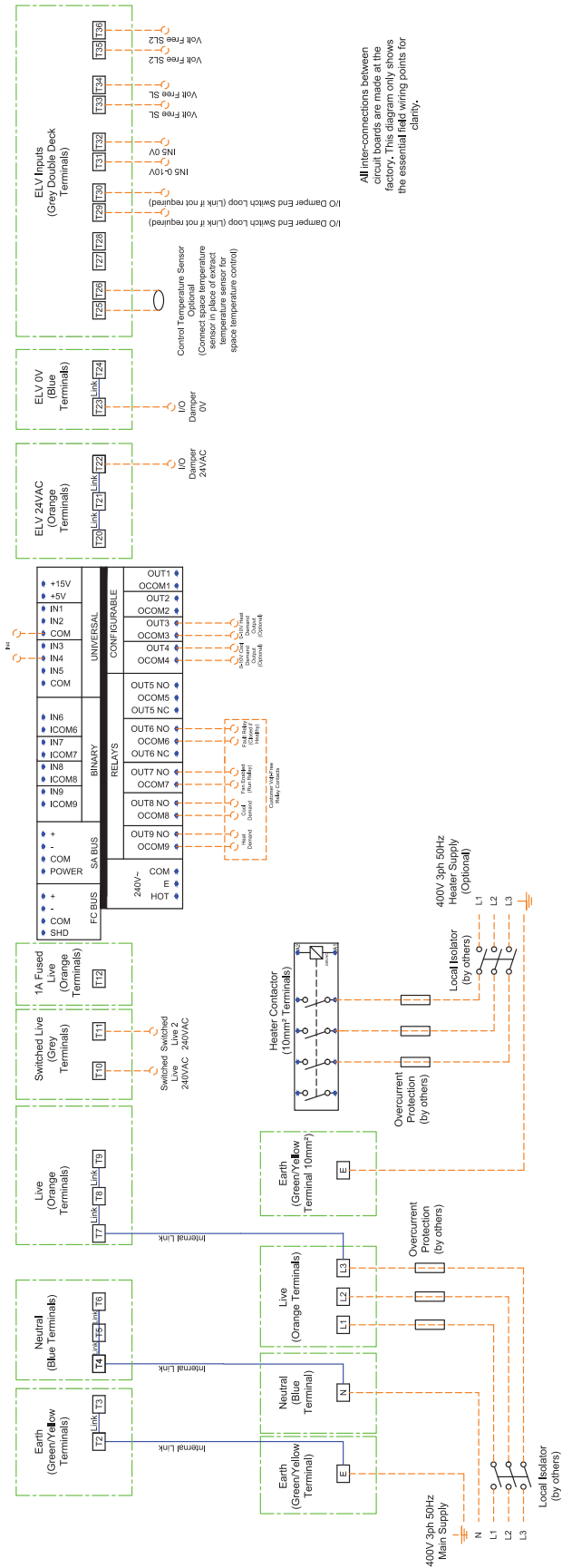
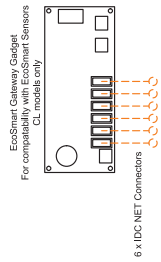

All inter-connections between circuit boards are made at the factory. This diagram only shows the essential field wiring points for clarity.

5.8.2 XBC10-15 Units with Electric Heating

30 Wiring - XBC10-15 Units with Electric Heating

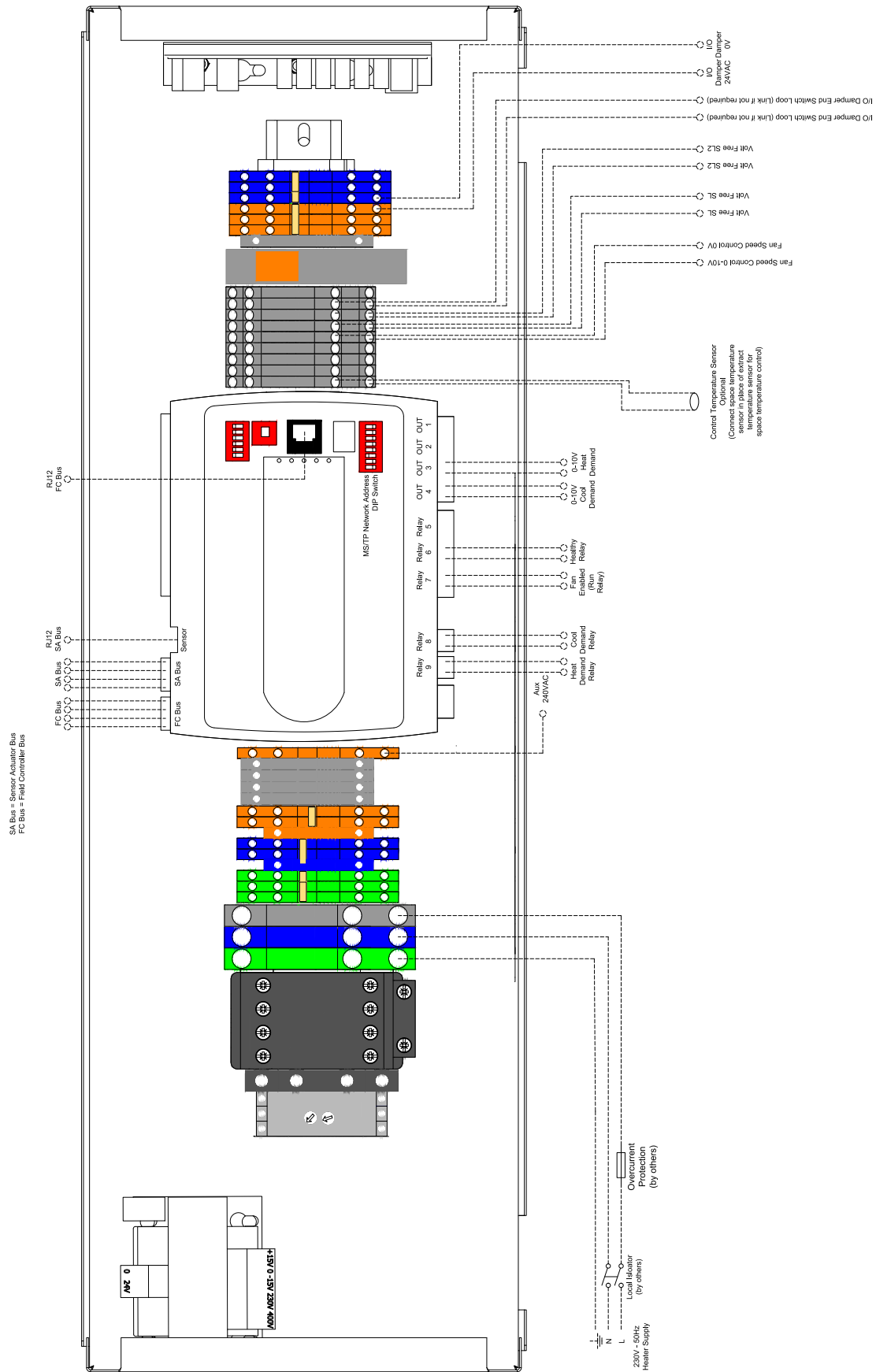

5.8.3 XBC25-65 With No / LPHW Heating

31 Wiring - XBC25-45 With No / LPHW Heating

Connect Control (No Heater/LPHW)

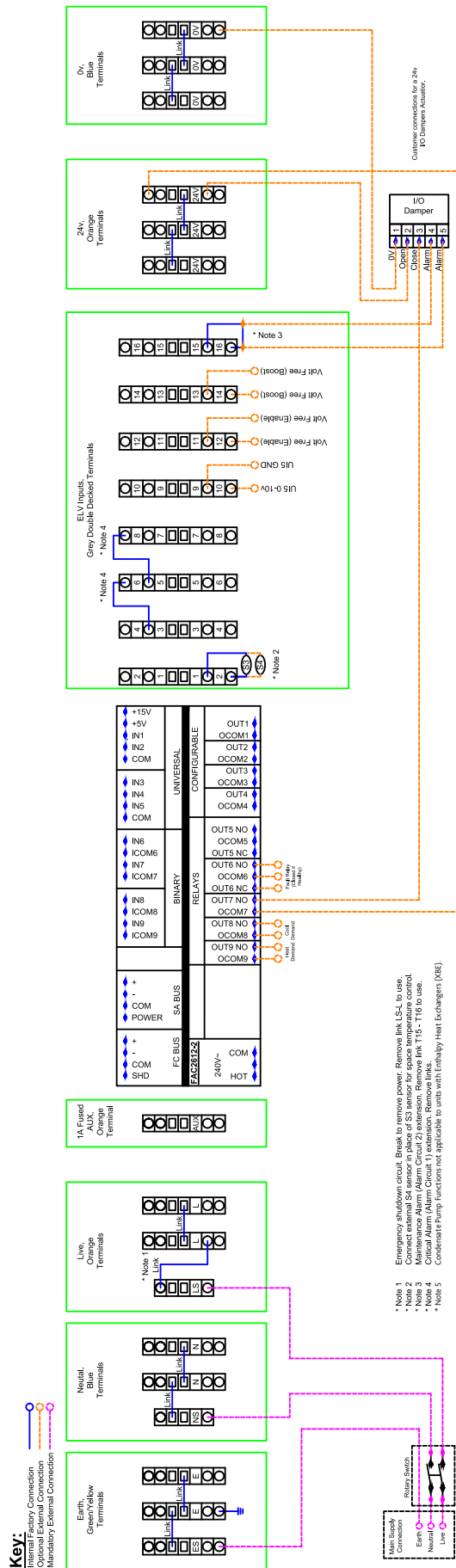

5.8.4 XBC55-65 With Electric Heating

32 Wiring - XBC55-65 With Electric Heating

Connect Control (Electric Heater)

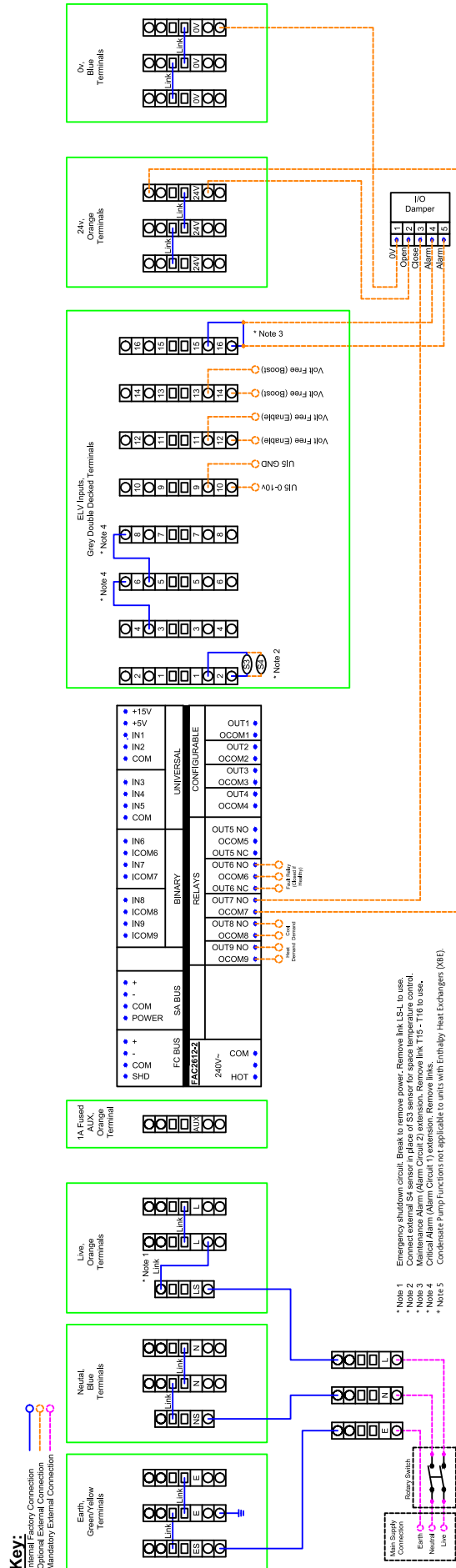

6.0 CONTROLS

See EcoSmart Connect control operation manual (document number 672040) for detailed controls information. A quick controls guide is also available (document number 671868).

7.0 COMMISSIONING

Before commissioning the unit, ensure that all equipment has been assembled in accordance with the installation procedure all instances where the unit is in operation the access doors should remain closed; at no time, during maintenance or otherwise, should anyone be inside a unit whilst it is in operation.

7.1 Fan & Motor

Care should be taken to ensure that the fan and motor run freely and that the fan is rotating in the correct direction.

The electrical current being drawn by motors should not exceed the manufacturers recommendations (specified on the motor plate). If the current exceeds this, check the fan volume flow rate and the static resistance.

7.2 Commissioning Checklist

- All equipment received is according to specification/order.
- Any damage to unit identified.
- Fan base shipping restraints / Fixing Brace removed (if applicable).
- The correct installation procedure has been carried out in accordance to Nuair's recommendations.
- Any fan and thermal wheel motor pulleys are properly aligned.
- Anti-vibration mounts are adjusted accordingly.
- Check / adjust fan and thermal wheel belt tension.
- Rotate fan impellers and motors to ensure they run freely.
- Check any additional bearings and couplings (where fitted manually).
- Condensate drain traps are checked. Check all filters are correctly fitted.
- Ensure ductwork is complete.
- Check electrical supply voltage and tightness of all electrical connections.
- Ensure control damper operation.
- Ensure access panels and doors are fitted properly and secure.
- Check fan motor current draw.

8.0 MAINTENANCE

It is important that maintenance checks are recorded and that the schedule is always adhered to, in all cases, the previous report should be referred to.

8.1 Routine Maintenance

- Clean all areas of unit and treat any areas of corrosion.
- Check all access doors for leakage and if necessary locks should be adjusted and any replacement gasket materials should be replaced as required.
- Any drain trays should be cleaned and repaired if necessary.

8.2 Every 3 Months

- Check filters and change/clean if required, failure to do so may impair the performance and energy efficiency of this unit.
- Ensure condensate drains are cleaned clear and that water can flow freely from unit.
- Check fin coil banks and heat exchangers. If necessary clean with a soft brush or vacuum. Check for signs of contamination.

8.3 Annually

- Thoroughly inspect the unit and its components for corrosion, acting immediately to treat/restore any damaged areas.
- All electrical terminals within the unit should be tightened.
- Check all earth connections.
- Check control dampers blades.
- Check operation of damper actuators and linkages and adjust as necessary.
- Coil faces should be inspected and any dust removed.

9.0 WARRANTY

Ecosmart Connect (C) Control units with a standard unit finish have a 5 year warranty. Ecosmart Connect (C) Control units with a coastal (C4) unit finish have a 1 year warranty. The warranty starts from the day of delivery and includes parts and labour for the first year. The remaining period covers replacement parts only.

This warranty is void if the equipment is modified without authorisation, is incorrectly applied, misused, disassembled, or not installed, commissioned and maintained in accordance with the details contained in this manual and general good practice. **Failure to maintain the unit as recommended will invalidate the warranty.**

The product warranty applies to the UK mainland and in accordance with Clause 14 of our Conditions of Sale. Customers purchasing from outside of the UK should contact Nuair International Sales office for further details.

10.0 END-OF-LIFE AND RECYCLING

Where possible Nuair use components which can be largely recycled when the product reaches its end-of-life:

- Fans, motors, controls, actuators, cabling and other electrical components can be segregated into WEEE recycling streams.
- Sheet metal parts, aluminium extrusion, heating/cooling coils and other metallic items can be segregated and fully recycled.
- EPP, plastic ducting, nylon corner pieces, plastic heat exchangers, packaging material and other plastic components can be segregated into mixed plastic and widely recycled.
- Cardboard packaging, wood, used filters and other paper components can be largely recycled or fully processed in energy from waste centres.
- Remaining Items can be further segregated and processed in accordance with the zero waste hierarchy. Please call After Sales Support for further information on items not listed above.

Ensure that Nuair product is made safe from any electrical / water / refrigerant supplies before dismantling commences. This work should only be undertaken by a qualified person in accordance with local authority regulations and guidelines, taking into account all site based risks.

11.0 AFTER SALES AND REPLACEMENT PARTS

For technical assistance or further product information, including spare parts and replacement components, please contact the After Sales Department.

If ordering spares please quote the serial number of the unit together with the part number, if the part number is not known please give a full description of the part required. The serial number will be found on the identification plate attached to the unit casing.

Telephone 02920 858 400
aftersales@nuaire.co.uk

Technical or commercial considerations may, from time to time, make it necessary to alter the design, performance and dimensions of equipment and the right is reserved to make such changes without prior notice.

